



SINO AGE DEVELOPMENT TECHNOLOGY

# HARDNESS TESTER HARTIP 4100

---

OPERATION MANUAL



**Sales and Service:**



BAQ GmbH  
Hermann-Schlichting-Straße 14  
38110 Braunschweig  
Germany

Phone +49 5307 95102 -0  
Fax +49 5307 95102 -20

<http://www.baq-inspection.vom>  
[info@baq.de](mailto:info@baq.de)

# CONTENTS

<b>1.</b>	<b>FOREWORDS.....</b>	<b>2</b>
1.1.	HISTORY.....	2
1.2.	LEEB HARDNESS TEST (DEFINITION).....	2
1.3.	NOTATION OF LEEB'S HARDNESS.....	2
<b>2.</b>	<b>FEATURES AND APPLICATIONS.....</b>	<b>3</b>
2.1.	INTRODUCTION.....	3
2.2.	SPECIFICATIONS.....	4
2.3.	APPLICATIONS.....	4
<b>3.</b>	<b>SYMBOLS AND ILLUSTRATIONS.....</b>	<b>5</b>
3.1.	SYMBOLS AND ILLUSTRATIONS.....	5
3.2.	MEASUREMENT AND CONVERSION TABLE.....	5
<b>4.</b>	<b>PREPARATION BEFORE MEASURING.....</b>	<b>6</b>
4.1.	REQUIREMENTS FOR THE SAMPLE.....	6
4.2.	REQUIREMENTS FOR THE WEIGHT OF THE SAMPLE.....	6
4.3.	REQUIREMENT FOR THE SURFACE HARDENED LAYER OF THE SAMPLE.....	7
4.4.	SAMPLES WITH CURVED SURFACES.....	7
<b>5.</b>	<b>OPERATION.....</b>	<b>8</b>
5.1.	LAYOUT OF INSTRUMENT.....	8
5.2.	BUTTON DESCRIPTION.....	8
5.3.	STRUCTURE OF MENUS.....	9
5.4.	ICONS DESCRIPTION.....	10
5.5.	MEASUREMENT SCREEN.....	11
5.6.	LANGUAGE MENU.....	14
5.7.	CONFIGURATION MENU.....	15
5.8.	MENU.....	24
5.9.	SHORTCUTS.....	34
<b>6.</b>	<b>OPERATION.....</b>	<b>35</b>
6.1.	START/SHUTDOWN.....	35
6.2.	OPERATION OF PROBE.....	36
6.3.	RE-READ, SAVE, DELETE AND PRINT MEASUREMENTS.....	37
6.4.	UPLOAD MEASUREMENT TO COMPUTER.....	39
6.4.1.	DRIVER INSTALLATION.....	39
6.4.2.	SOFTWARE INSTALLATION.....	40
6.4.3.	START PC SOFTWARE.....	40
<b>7.</b>	<b>MAINTENANCE OF PROBE.....</b>	<b>41</b>
<b>8.</b>	<b>ACCESSORIES.....</b>	<b>42</b>
8.1.	THERMAL PRINTER.....	42
8.2.	SHAPED SUPPORT RING.....	44
<b>9.</b>	<b>CALIBRATION OF INSTRUMENT.....</b>	<b>46</b>
9.1.	CALIBRATION APPLICATIONS.....	46
9.2.	SETTING OF CALIBRATION.....	46
<b>10.</b>	<b>Q&amp;A.....</b>	<b>47</b>
10.1.	ABOUT CONFIGURATION MENU.....	47
10.2.	ABOUT MENU.....	47
10.3.	ABOUT WIRELESS APPLICATIONS.....	47
10.4.	ABOUT USB COMMUNICATION.....	48
10.5.	ABOUT MEASUREMENTS.....	48
10.6.	Wireless Micro printer.....	49

# 1. Forewords

## 1.1. History

The Leeb measuring method was first brought into measurement technology in 1978. It is defined as the quotient of an impact body's rebound velocity over its impact velocity, multiplied by 1000. Harder materials produce a higher rebound velocity than softer materials. For a specific group of material (e.g. steel, aluminum. etc.), Leeb hardness value represents a direct relationship to its hardness properties. For ordinary metal, conversion curves of hardness HL versus other standard static hardness (HB, HV, HRC, etc.) are available, enabling you to convert HL into other hardness values.

## 1.2. Leeb Hardness Test (definition)

An impact body with a spherical test tip made of tungsten carbide is propelled against the sample surface by a spring force and then rebounds back. At a distance of 1mm from the sample surface, the impact and rebound velocity of the impact body are measured by the following method: A permanent magnet embedded in the impact body, when passing through the coil in its coil holder, induces in the coil an electric voltage proportional to the velocities of the magnet. Leeb hardness is expressed by the following formula:

$$HL = \frac{V_r}{V_i} * 1000$$

Where:

HL is Leeb Hardness

$V_r$  is the rebound velocity of the impact body

$V_i$  is the impact velocity of the impact body

The voltage characteristic of output signal, when the impact body passes through the induction coil is illustrated in the following figure:

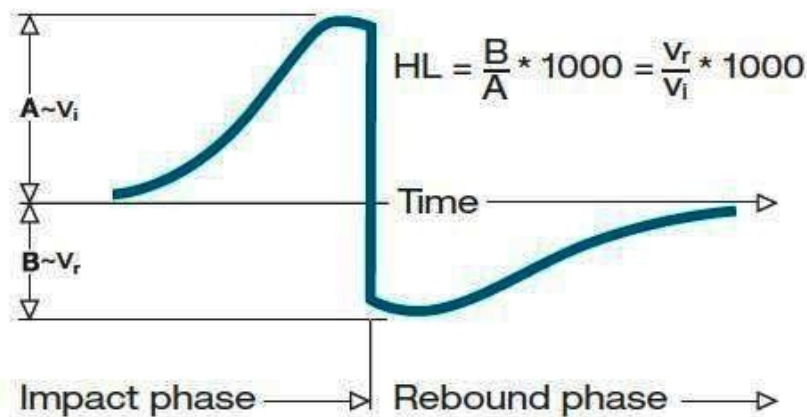

*Voltage characteristic of output signal*

A Leeb's Hardness Tester measures the hardness of sample material in terms of Hardness Leeb (HL), which can be converted into other Hardness units (Rockwell B and C, Vicker, Brinell and Shore D).

## 1.3. Notation of Leeb's Hardness

When measuring the hardness of a sample material using the traditional static hardness testing method, a change of applied pressure will result in a change in the hardness reading. This will also happen during a Leeb's Hardness test when one changes the impact device. In hardness measurement of the same test sample with different impact devices, the Leeb's hardness values obtained will vary.

For example: 720HLD≠720HLC

Because different converting curves are obtained from different impact devices, when converting hardness HL into another hardness values, the notation for the converted hardness value should include the impact device used.

For example:

Hardness HRC converted from hardness L using impact device D should be written as 35, 9 HRCLD.

Where:

35=Hardness value HL  
9=Hardness value HRC  
L=Leeb's Method  
D=Impact device

## **2. Features and Applications**

### **1.4. Introduction**

This instrument is an advanced state-of-the-art palm sized metal hardness tester with many new features which are light weight, easy operation, integrated design, high contrast display, low operating temperature, auto compensating for impact direction and etc. It can be widely used for measuring hardness of almost all ferrous and non-ferrous metal materials for scale of Leeb hardness, Rockwell C, B &A, Brinell, Vickers, Shore and Strength.

It has a memory which can be downloaded to computer via USB port or wirelessly. The measuring value can be printed out from tester to micro-printer or from PC. All stored data can be recalled and read on the tester easily.

It also has a very unique feature, its impact device can convert between D and DL simply by changing impact body. This two-in-one probe is equivalent to two individual probes. With this optional accessory, you can take measurement at very narrow surface such as slot bottom, gear tooth that probe D cannot match.

The 3.7V Li-ion rechargeable battery inside the tester can be charged via USB from PC or via individual USB charger from mains wall power. With data software for PC, customers can download measuring values from the tester to PC and make process such as save, delete, create testing report and export them to Excel.

## 1.5. Specifications

Specifications	HARTIP4100
Accuracy	+/-2HL (or +/-0.3%@HL=800)
Display resolution	1HL, 0.1HRC
Display	320*320 high contrast color TFT
Impact device	D (Default) / D-DL 2 in 1 (Optional)
Impact direction	Universal angle, no need to setup impact direction
Viewing style	4 styles
Hardness scale	HL / HRC / HRB / HB / HV / HS / HRA / SGM( $\sigma_b$ )
Measuring range	HL100-960 / HRC1-78.7 / HRB1-140 / HB1-1878 / HV1-1698 / HS1.0-131 / HRA7-88.5 / $\sigma_b$ (rm)24-6599N/mm <sup>2</sup>
Materials	12 common metal materials
Memory	31 files, 100 data for each file
Statistics	mean, max., min., extreme deviation, standard deviation, column chart, dynamic doughnut chart
Interface	USB/Bluetooth to PC for transferring data or printing, USB for charging
Recalibration	allowed by user
Alarm	Up or down limit
Indicator	Low battery
Power supply	3.7V Li-ion rechargeable battery
Power on/off	Auto or manually
Operating environment	-20°C ~+70°C
Dimension (LxWxD)	145mm×45mm×20mm
Net weight	115g
Standards	Conforming to ASTM A956, DIN 50156, GB/T 17394-1998

## 1.6. Applications

- ✧ Hardness tests on installed machines or steel structures: e.g. on heavy and large work-piece or on permanently installed system parts.
- ✧ Rapid testing of multiple measuring areas for examination of hardness variations over larger regions.
- ✧ Measuring hardness for produced parts at production line.
- ✧ Identifying metallic material stored in a warehouse.
- ✧ Ineffectiveness analysis of permanent parts, pressure -vessel, turbo generator.

### 3. Symbols and Illustrations

#### 1.7. Symbols and Illustrations

Symbols	Illustrations
HLD	Leeb hardness value used with impact device D
HLDL	Leeb hardness value used with impact device DL
HB	Brinell hardness value
HRB	Rockwell B hardness value
HRC	Rockwell C hardness value
HS	Shore hardness value
HV	Vickers hardness value
HRA	Rockwell A hardness value
$\sigma_b$ (N/mm <sup>2</sup> )	Strength value

#### 1.8. Measurement and Conversion Table

Range for measurement and conversion:

IMPACT DEVICE D HL: 170-960							
MATERIALS	HRC	HRB	HB	HV	HS	HRA	$\sigma_b$ (N/mm <sup>2</sup> )
STEEL/CAST STEEL	0.1-74.7	1.2-140	28-1027	45-1230	4.0-112	7-88.5	118-3315
ALLOY TOOL STEEL	0.9-78.7		15-1878	32-1698	5.5-128		79-6599
STAINLESS STEEL	3.7-62.4	8.3-101.7	85-655	36-802	6-131		108-1725
LAMELLAR IRON	21-59	24-100	35-570	90-698	6-83		
NODULAR IRON	21-60	24-100	62-857	96-724	8-90		
CAST ALUMINUM	1-48	24-85	19-445	22-193	3-64		129-2618
COPPERZINC BRASS	1-53	1.5-99.6	32-477	29-495	5-65	32-76	258-4146
BRONZE	1-56	14-100	15-505	11-535	2-68	29-76	190-1860
WROUGHT COPPER	1-54	14-100	35-569	38-590	6-73		
FORGING STEEL	1-72		50-1060	48-1110	7-103		200-3750
MILL ROLLER	1-72		82-1380	83-1440	14-117.8		310-4860
CHINESE STEEL	20-67.9	59.6-99.5	80-647	80-940	32.5-99.5	30-88	375-1710

IMPACT DEVICE DL DL: 170-960							
MATERIALS	HRC	HRB	HB	HV	HS	HRA	$\sigma_b$ (N/mm <sup>2</sup> )
STEEL/CAST STEEL	1-69.8	1.5-109.5	3-915	1.0-1017	1-100		34-3100
ALLOY TOOL STEEL	2.4-75.2		5-1240	2.0-1095	1-111.6		38-4200
NODULAR IRON	13-76	38-110	8-1090	2-102			
CAST ALUMINUM	1-55	2-112	3-660	12-602	3-74		

## 4. Preparation before Measuring

### 1.9. Requirements for the sample

The surface temperature of sample should be less than 120 °C.

The samples must feature a metallic smooth, ground surface, in order to eliminate erroneous measurements brought about by coarse grinding or lathe scoring. The roughness of the finished surface should not exceed 2µm.

### 1.10. Requirements for the weight of the sample

For samples weighing over 5 kg and of compact shape, no support is needed.

Samples weighing between 2-5 kg, and also for heavier samples with protruding parts or thin walls, should be placed on a solid support in such a manner that they do not bend or move by the impact force.

Samples weighing less than 2 kg should be firmly coupled with a stable support weighing over 5 kg.

For coupling purposes,

- ✧ The coupling surface between the sample and base plate should be flat, plane parallel and ground.
- ✧ A thin proper layer of coupling paste is to be applied to the contact surface of the sample.
- ✧ The sample should be firmly pressed against the surface of the base plate by moving it with a circular motion.
- ✧ The direction of impact should be perpendicular to the coupling surface.
- ✧ For the coupling operation, the following prerequisites must be fulfilled:
  - ✧ The contact surface of the sample and the surface of the base plate must be flat, plane parallel and ground.
  - ✧ The direction of the test impact must be perpendicular to the coupled surface.
  - ✧ Minimum thickness of the sample for coupling (5mm).

Proper Coupling:

Proper coupling requires a little experience. Insufficiently coupled samples produce large variations of individual measurements, L-values which are too low and the operation is characterized by a rattling noise upon impact of the test tip.

Example for coupling a test piece with a base plate:

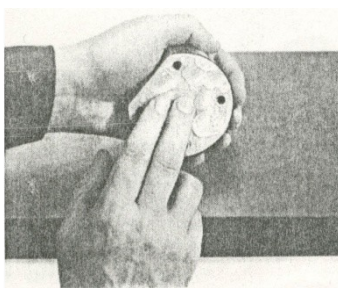

Application of the coupling paste (As thin as possible).

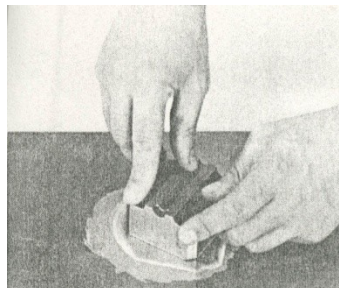

Mutual rubbing of both parts while firmly press the sample against the base plate.

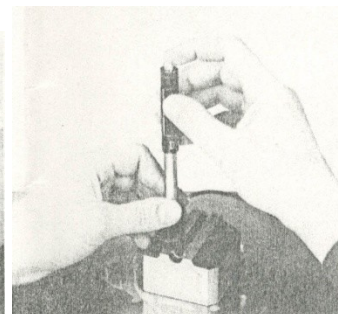

A particular advanced of coupling is the possibility of obtaining a very uniform, rigid connection between the sample and the support, totally eliminating stresses at the sample surface. The resulting variation in measured values is very low.



### 1.11. Requirement for the surface hardened layer of the sample

Surface -hardened steels and especially case-hardened steels produce L-values which are too low when case-hardening depth is small because of their soft core. When measuring with impact device D/DL the depth of the hardened layer should be no less than 0.8 mm.

Surface of the test sample should not be magnetic.

For test sample of curving surface with radius of curvature R less than 30mm, a small support ring should be used.

Supporting the Samples during Testing

Type of impact device	Classification of samples		
	heavy	medium-weight	light-weight
D/DL	more than 5 kg	2 - 5 kg	0.05 - 2 kg

When measuring hardness with this tester, the following has to be noticed: Despite the low mass of the impact body and low impact energy, a relatively large impact force of short duration is generated when the impact body hits the measuring surface. The max. impact force of impact device D/DL is 900N.

For heavy samples of compact shape, no particular precautions are necessary.

Smaller and lighter samples or work pieces yield or flex under this force, producing L-values which are too small and of excessively large variation. Even with big or heavy work pieces it is possible for thin-wall regions or thinner protruding parts to yield upon impact. Depending on the frequency of the resilient yielding action, the measured L-value may be too small or too large. In many situations, potential problems can be checked in the following manner:

a) Medium-weight samples and also heavier samples with protruding parts or thin walls should be placed on a solid support in such a manner that they do not move or flex during the test impact.

b) Light-weight samples should be rigidly “coupled” with a non-yielding support such as a heavy base plate. Clamping in a vice is of no value, since the samples become exposed to stress and because complete rigidity is never attained. As a rule, the measured L-values would be too small and show excessive variations.

### 1.12. Samples with Curved Surfaces

Impact testers only work properly if the impact body has a certain position in the guiding tube at the moment of impact. In the normal position when testing flat and convex-cylindrical samples (such as round samples), the spherical test tip is located exactly at the end of the guiding tube.

However, when testing spherically or cylindrically shaped concave surfaces, the impact body remains further within the guide tube or protrudes further therefore. Thus, with such types of curved surfaces, it should be observed that the radius of curvature R is larger than the values indicated in the following Figure.

Curved surfaces should always be tested with the small support ring.

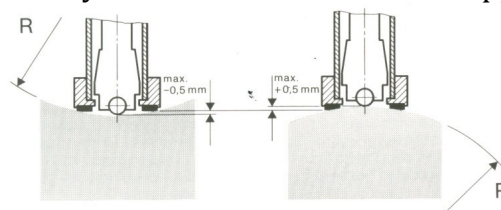

Impact device types D  $R_{min}=30mm$

For impact devices D, special support rings are available to accommodate smaller radii on convex or concave surface.

## 5. Operation

### 1.13. Layout of instrument

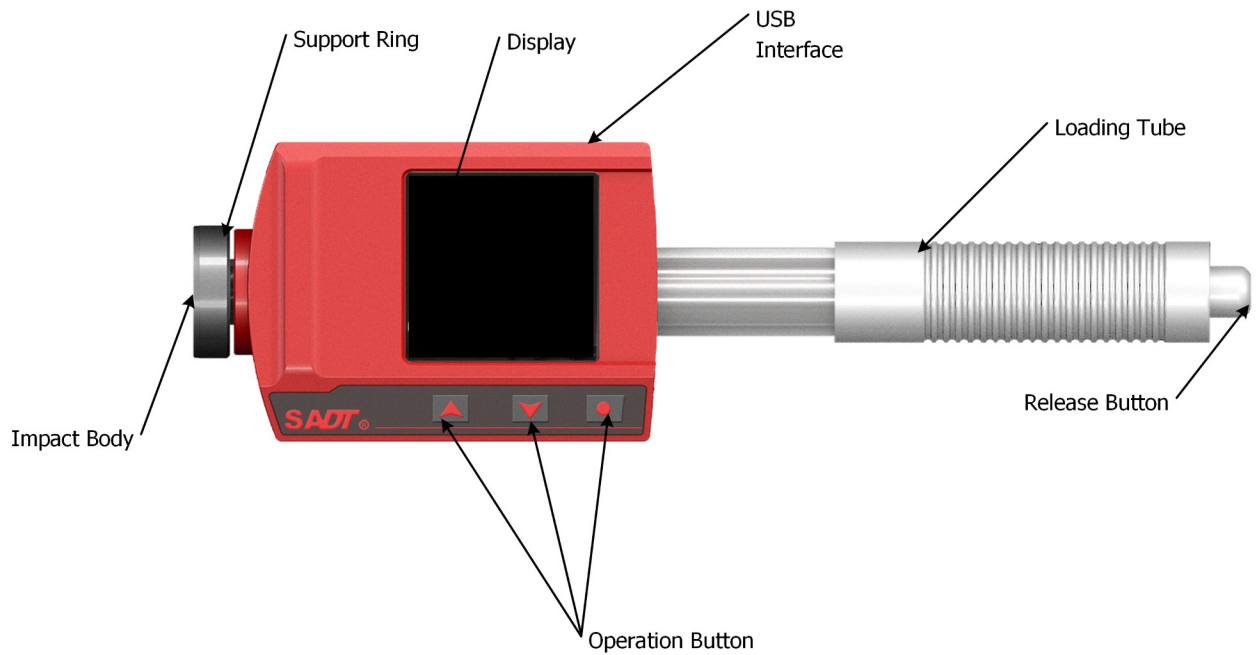







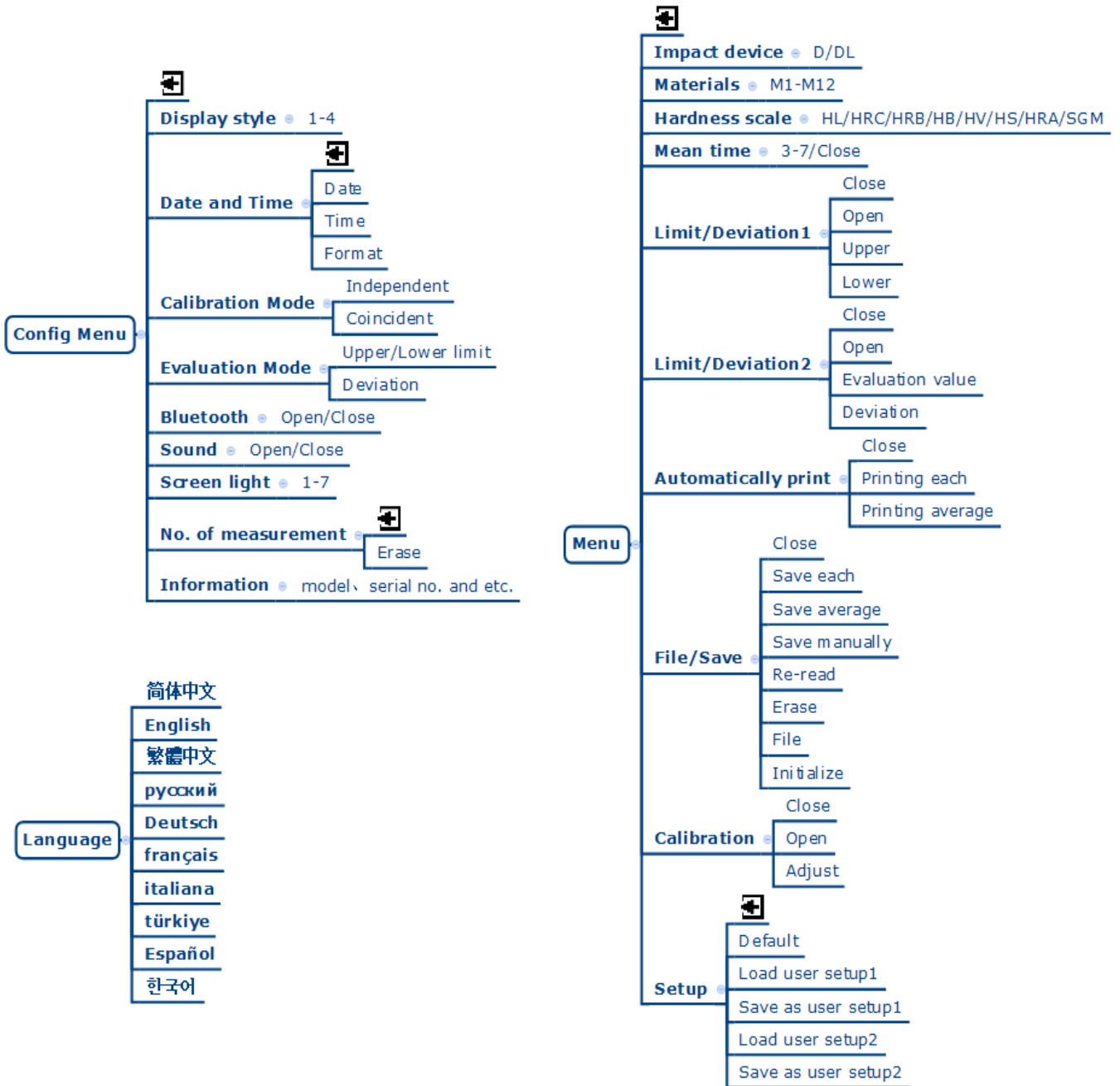













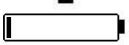

### 1.14. Button description

▼	▲	● (Power On/Off)
Menu key, press it to enter main menu Downward key, press it to move cursor downward	Press it shortly to enter config menu Press and hold it to enter language menu Upward key, press it to move cursor upward	Press it to switch on the tester Press and hold it to switch off the tester Confirm the selection Press it on measuring mode to save/print/delete current reading

## 1.15. Structure of Menus



### 1.16. Icons Description

Type of icon	Icon	Introduction
External battery		Battery empty
		Battery level: 20%
		Battery level: 40%
		Battery level: 60%
		Battery level: 80%
		Battery level: 100%
Print		Enable Automatically Print
Communication		Bluetooth port (already paired)
		Bluetooth port (not paired)
Calibrate		Enable calibration
Upper/Lower limits		Enable Upper/Lower limits
Average		Average Number: Average - current number
Booting display		Enable Calibration, o only display during booting
		Battery empty, only display during booting
User operation		Exiting the window
		Save failed
		Deleted successfully
		Wrong
		Invalid
		Successful
		Working, please wait
		Functions needing upgrade
File		Re-read
Data area	↑ or ▲	Exceed upper limit
	↓ or ▼	Exceed lower limit
	*	Coarse error

### 1.17. Measurement Screen

The Measurement screen consists of Data display area and top/bottom status bar. There are four types of Data display areas: large font display, statistical parameter display, histogram display and dynamic ring display.

#### 1.17.1. Measurement Screen-Status Bar

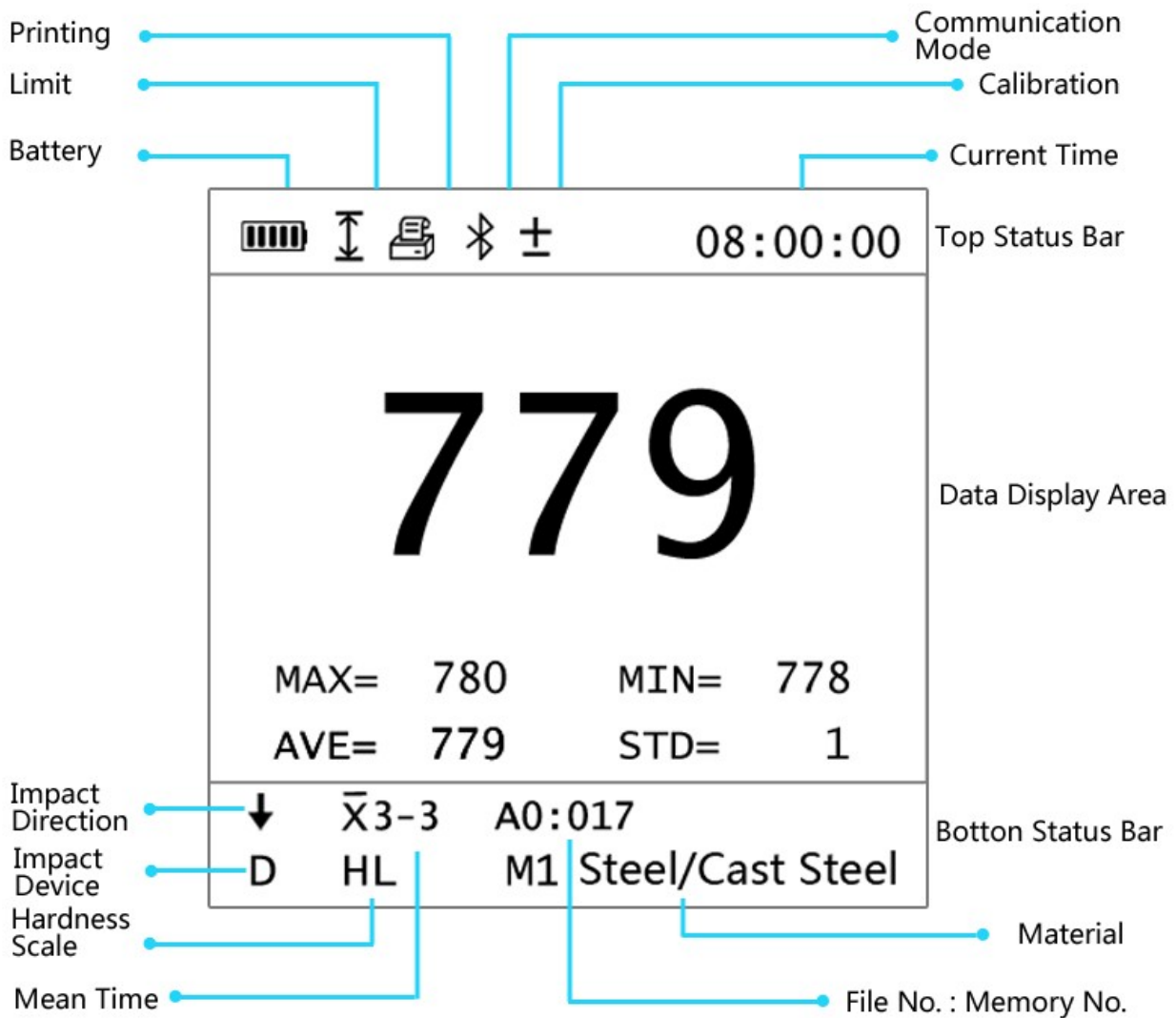

Screen Description

### 1.17.2.Measurement Screen - Large Font Display

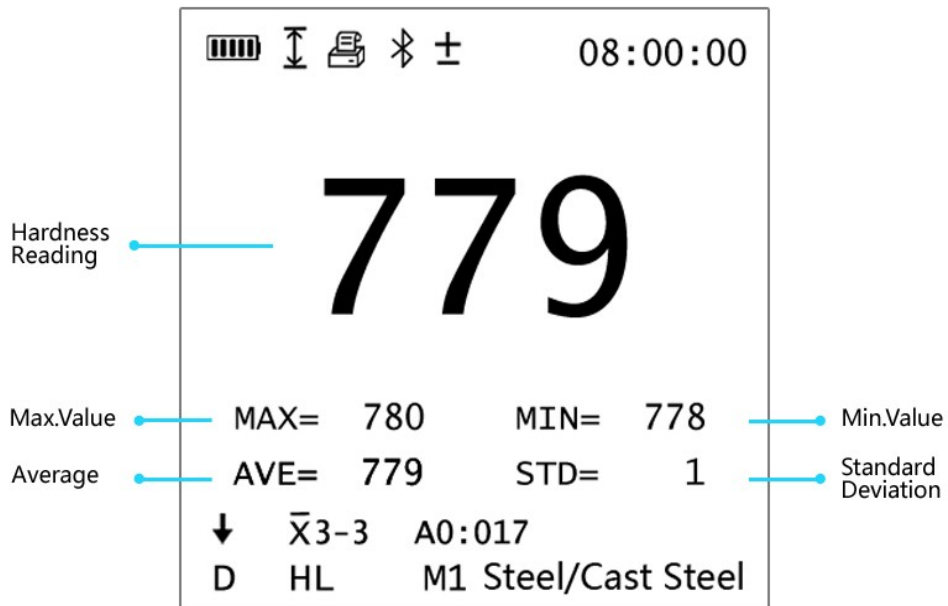

### 1.17.3.Measurement Screen - Statistical Parameter Display

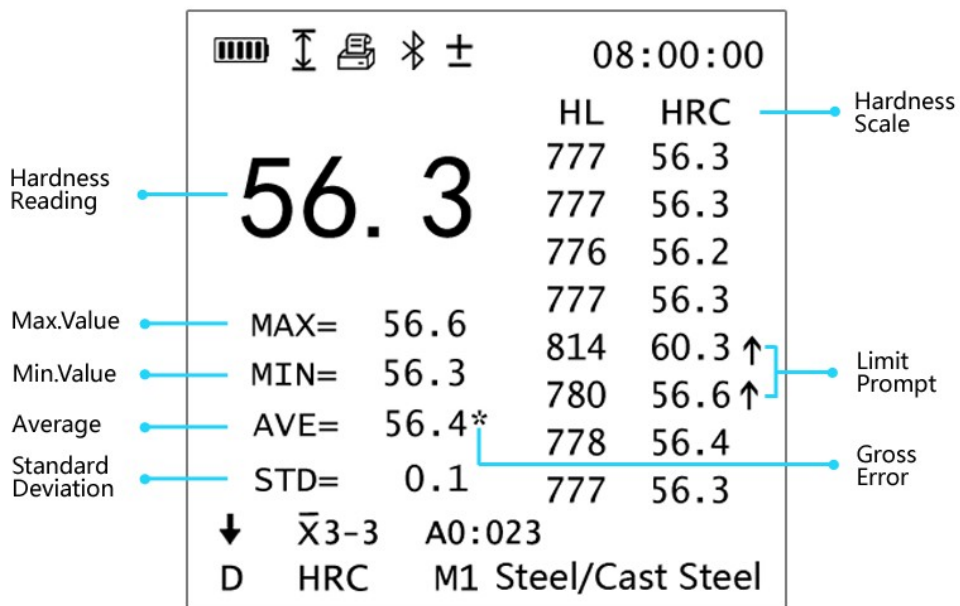

### 1.17.4. Measurement Screen - Histogram Display

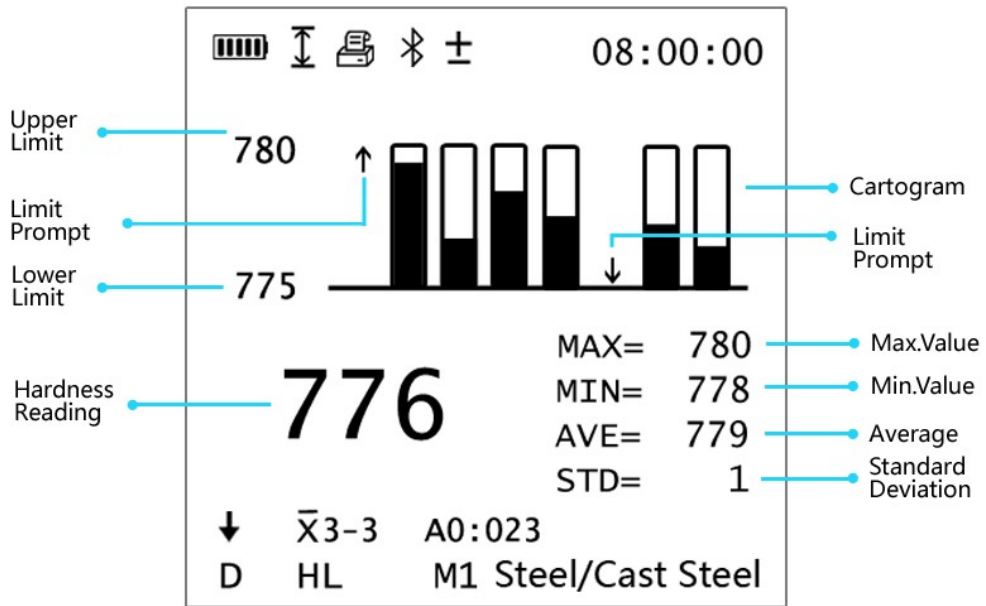

### 1.17.5. Measurement Screen - Dynamic Ring Display



### 1.18. Language Menu

#### 1. Entry

Press and hold ▲ in Measurement screen to enter Language Menu screen.

#### 2. Operation

	<p>Press ▼ or ▲ to move the option;          Press ● to confirm and exit;          Press and hold ● to exit without changing the text.</p>
Select Language	Key operation

For example, the corresponding changes to the screen and display after selecting Traditional Chinese.

Screen in Traditional Chinese	Menu in Traditional Chinese

#### 3. Meaning of menu

For Model 4100, there are ten languages including Simplified Chinese and Traditional Chinese, such as English, Russian, German and French etc. The users can choose their language as required.



## 1.19. Configuration Menu

### 1. Entry

Press ▲ in Measurement screen to enter Configuration Menu screen.

### 2. Operation

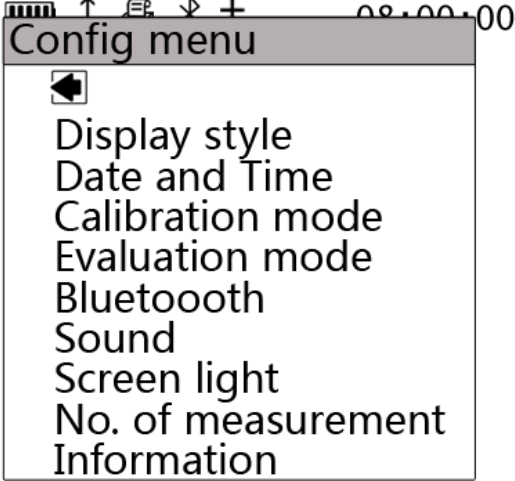
	<p>Press ▼ or ▲ to move the option;          Press ● to enter the option;          Press and hold ● to exit and return to Measurement screen.          Press ⏏ to exit.</p>
Configuration Menu	Key operation

### 3. Meaning of menu

There are nine Configuration Menu items, mainly used for settings of the instrument. For example, you can set Display Style, Date and Time, Calibration Mode, etc.

### 1.19.1. Display Style



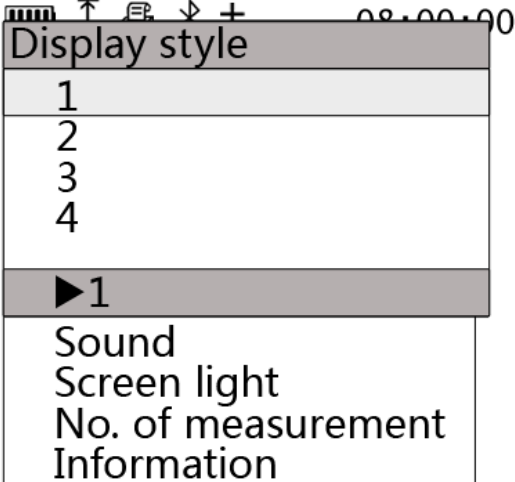

#### 1. Entry

Press ▲ in Measurement screen to enter Configuration Menu screen. Press ▲ or ▼ to select Display Style and press ● to enter Display Style screen.

#### 2. Operation

	<p>Press ▼ or ▲ to move the option;          Press ● to confirm and exit;          Press and hold ● to confirm and return to Measurement screen.</p> <p>1-4 mean four display styles. Select any one, the Measurement screen immediately changes.</p>
Display Style	Key operation

The four styles are as follows:

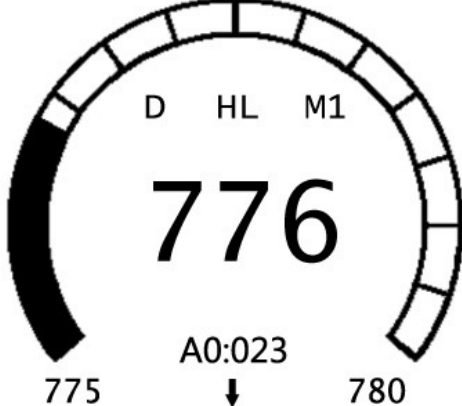
 08:00:00 <h1 style="text-align: center;">779</h1> <p>MAX= 780      MIN= 778          AVE= 779      STD= 1</p> <p>↓ <math>\bar{X}</math>3-3    A0:017          D   HL      M1 Steel/Cast Steel</p>	 08:00:00 <div style="display: flex; justify-content: space-between;"> <span>HL    HRC</span> </div> <h1 style="text-align: center;">56.3</h1> <table style="width: 100%; border-collapse: collapse;"> <tr><td style="width: 150px;"></td><td style="text-align: right;">777</td><td style="text-align: right;">56.3</td></tr> <tr><td></td><td style="text-align: right;">777</td><td style="text-align: right;">56.3</td></tr> <tr><td></td><td style="text-align: right;">776</td><td style="text-align: right;">56.2</td></tr> <tr><td></td><td style="text-align: right;">777</td><td style="text-align: right;">56.3</td></tr> <tr><td>MAX=</td><td style="text-align: right;">56.6</td><td style="text-align: right;">814 60.3 ↑</td></tr> <tr><td>MIN=</td><td style="text-align: right;">56.3</td><td style="text-align: right;">780 56.6 ↑</td></tr> <tr><td>AVE=</td><td style="text-align: right;">56.4*</td><td style="text-align: right;">778 56.4</td></tr> <tr><td>STD=</td><td style="text-align: right;">0.1</td><td style="text-align: right;">777 56.3</td></tr> </table> <p>↓ <math>\bar{X}</math>3-3    A0:023          D   HRC    M1 Steel/Cast Steel</p>		777	56.3		777	56.3		776	56.2		777	56.3	MAX=	56.6	814 60.3 ↑	MIN=	56.3	780 56.6 ↑	AVE=	56.4*	778 56.4	STD=	0.1	777 56.3
	777	56.3																							
	777	56.3																							
	776	56.2																							
	777	56.3																							
MAX=	56.6	814 60.3 ↑																							
MIN=	56.3	780 56.6 ↑																							
AVE=	56.4*	778 56.4																							
STD=	0.1	777 56.3																							
Display Style 1																									
 08:00:00  <h1 style="text-align: center;">776</h1> <p>MAX= 780          MIN= 778          AVE= 779          STD= 1</p> <p>↓ <math>\bar{X}</math>3-3    A0:023          D   HL      M1 Steel/Cast Steel</p>	 08:00:00  <h1 style="text-align: center;">776</h1> <p style="text-align: center;">A0:023 ↓</p>																								
Display Style 3																									
Display Style 4																									

### 3. Meaning of menu

Choose a display style according to preferences and the brightness of the ambient light. Display Style 1 is set for large font display with super-large test result display and maximum/minimum data processing display. Display Style 2 is set for statistical parameter display to show the current value and statistics processing and list the first 8 data. Display Style 3 is set for histogram display of 8 data by compare. Any value exceeding Upper/Lower limit is indicated by red arrow. Display Style 4 is set for dynamic ring display, generally for enable Upper/Lower Limit/Deviation. The ring range is lower limit - upper limit. When the Upper/Lower Limit is enabled and the value is displayed, the ring dynamically displays the test results from left to right. The Upper/Lower Limit proportions for the data are displayed. When the evaluation value is enabled, the ring is divided into two parts. The middle data is the determining value. The left/right value is the determining value plus/minus the offset, respectively.

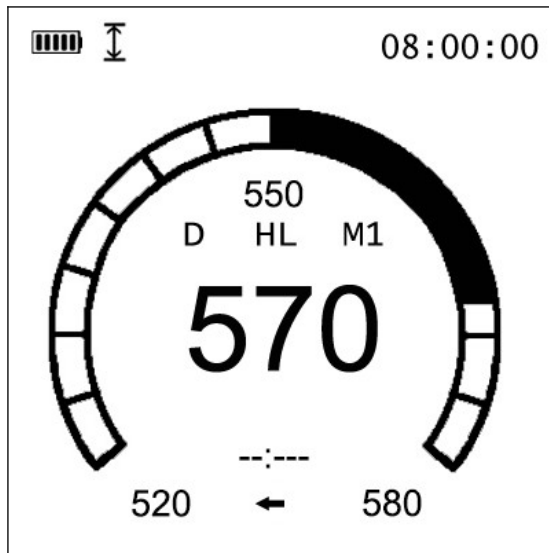

When the testing value is lower than the evaluation value, the ring display moves clockwise. When the testing value is higher than the evaluation value, the ring display moves anti-clockwise. When the upper or lower limit is exceeded, the test result changes to red.

### 1.19.2. Date and Time

#### 1. Entry

Press ▲ in Measurement screen to enter Configuration Menu screen. Press ▲ or ▼ to select Date and Time, and press ● to enter Date and Time screen.

#### 2. Operation

	<p>Press ▼ or ▲ to move the option;          Press ● to confirm and exit;          Press Time to set system time;          Press Date to set the system date;          Press Format to select format of date;          Press [Exit] to exit.</p>
Date and Time	Key operation

#### 5.1.1.1. Time

#### 1. Entry

Press ▲ in Measurement screen to enter Configuration Menu screen. Press ▲ or ▼ to select Date and Time, and press ● to enter Date and Time screen.

Press ▲ or ▼ in Date and Time screen to select Time and press ● to enter Time screen.

#### 2. Operation

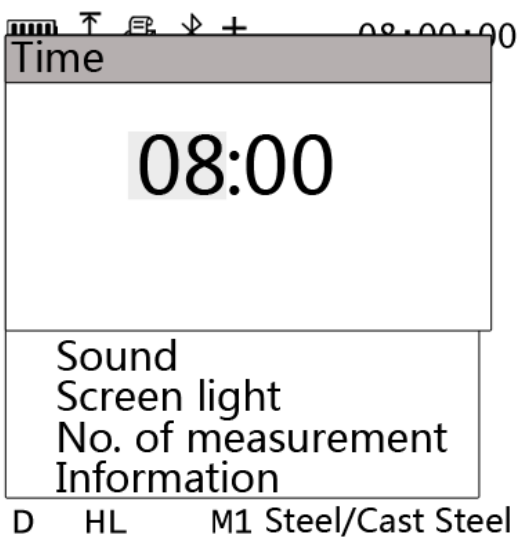
	<p>Press ● to select Hour/Min.  Press ▼ or ▲ to adjust the value.  Press and hold ● to confirm and exit after showing √.</p>
Time	Key operation

3. Meaning of menu

The setting for time is the basic setting to obtain time-related data.

**5.1.1.2. Date**

1. Entry

Press ▲ in Measurement screen to enter Configuration Menu screen. Press ▲ or ▼ to select Date and Time and press ● to enter Date and Time screen.

Press ▲ or ▼ in Date and Time screen to select Date and press ● to enter Date screen.

2. Operation

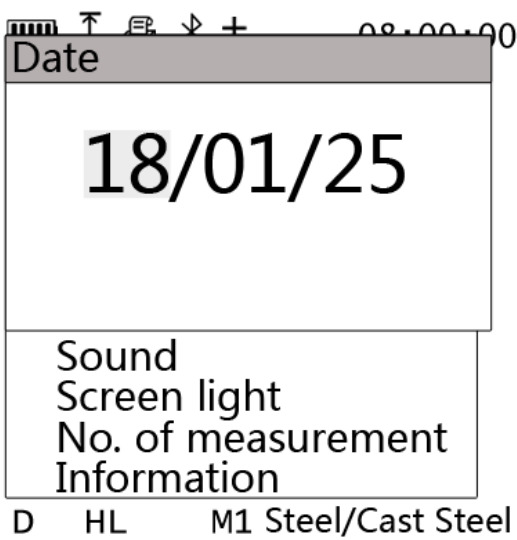
	<p>Press ● to select Year/Month/Day.  Press ▼ or ▲ to adjust the value.  Press and hold ● to confirm and exit after showing √.</p>
Date	Key operation

3. Meaning of menu

The setting for date is the basic setting to obtain date -related data.

**5.1.1.3. Format**

1. Entry

Press ▲ in Measurement screen to enter Configuration Menu screen. Press ▲ or ▼ to select Date and Time, and press ● to enter Date and Time screen.

Press ▲ or ▼ in Date and Time screen to select Format, and press ● to enter Format screen.

### 2. Operation

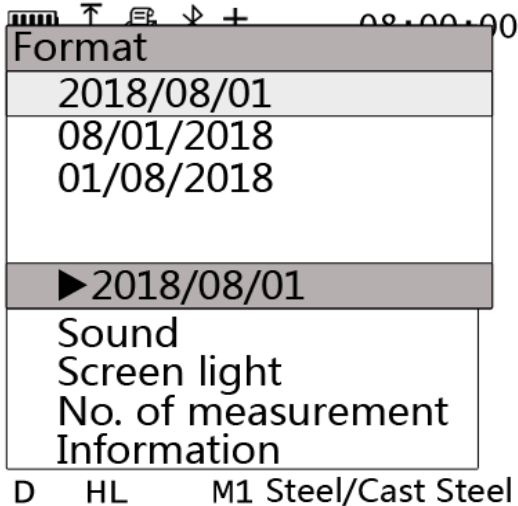
	<p>Press ● to select the format.          Press (and hold) ● to confirm and exit after showing √.          Date format: Year/Month/Day, Month/Day Year, Day/Month/Year.</p>
Format	Key operation

### 3. Meaning of menu

The setting for format is to select the convenient date format.

### 1.19.3. Calibration Mode

The Model 4100 provides Independent Mode and Coincident Mode for calibration. For calibration details, see Section 10 Calibration of Instrument.

### 1. Entry

Press ▲ in Measurement screen to enter Configuration Menu screen. Press ▲ or ▼ to select Calibration Mode, and press ● to enter Calibration Mode screen.

### 2. Operation

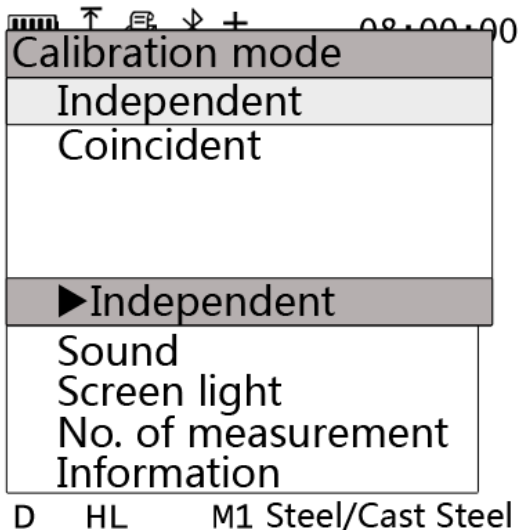
	<p>Press ▲ or ▼ to move the option;          Press ● to confirm and exit, or enter the upper/lower level window;          Press and hold ● to confirm and return to Measurement screen, or enter the upper/lower level window.          Independent Mode and Coincident Mode are calibration method.</p>
Calibration Mode	Key operation

### 3. Meaning of menu

When Independent Mode is selected, the hardness value of the selected scale can be calibrated, and the hardness values of other scales do not change. The coincident Mode is the

traditional calibration method, which is used to calibrate the Leeb hardness data. The data of other scales will change following the calibrated Leeb hardness data.

#### 1.19.4. Evaluation Mode

##### 1. Entry

Press ▲ in Measurement screen to enter Configuration Menu screen. Press ▲ or ▼ to select Evaluation Mode, and press ● to enter Evaluation Mode screen.

##### 2. Operation

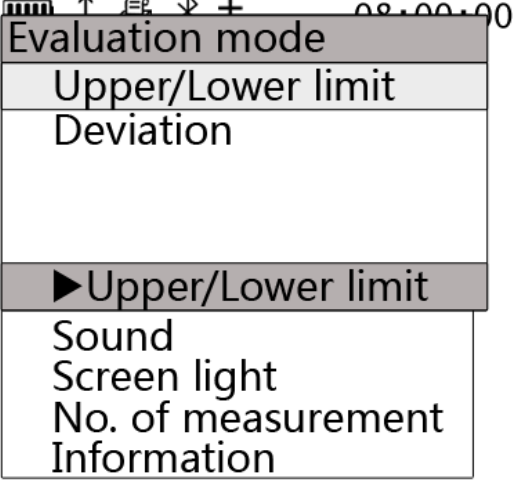
	<p>Press ▲ or ▼ to move the option;          Press ● to confirm and exit;          Press and hold ● to confirm and return to Measurement screen.          Select Upper/lower Limits to enable judgment by Upper/lower Limit;          Select Deviation to enable judgment by Deviation.</p>
Evaluation Mode	Key operation

##### 3. Meaning of menu

Select Evaluation Mode to judge whether the measurement range overruns.

When Upper/lower Limit is selected, the test result is normal when it is between the upper limit and the lower limit; otherwise, it exceeds the range. The user needs to set the Upper/Lower limit in the Upper/Lower Limits/Deviation in Menu screen, e.g., set the upper limit to 780 and the lower limit to 770. The measurement range is 770-780. If the value exceeds the range, the alarm is given.

When Evaluation Mode is selected, the test result will be based on a judgment value, such as 775, plus or minus an offset (5), the range is 770-780. In Display Style 1-3, the difference is minor. The user can select the configuration. This setting is particularly useful in Display Style 4 with a noticeable difference in the screen.

##### Note

When Display Style 4 is selected, select Upper/Lower Limit, the range is dynamically displayed from left to right; select Evaluation Mode, the range is dynamically displayed from middle to left/right.

#### 1.19.5. Bluetooth



##### 1. Entry

Press ▲ in Measurement screen to enter Configuration Menu screen. Press ▲ or ▼ to select Bluetooth, and press ● to enter Bluetooth screen.

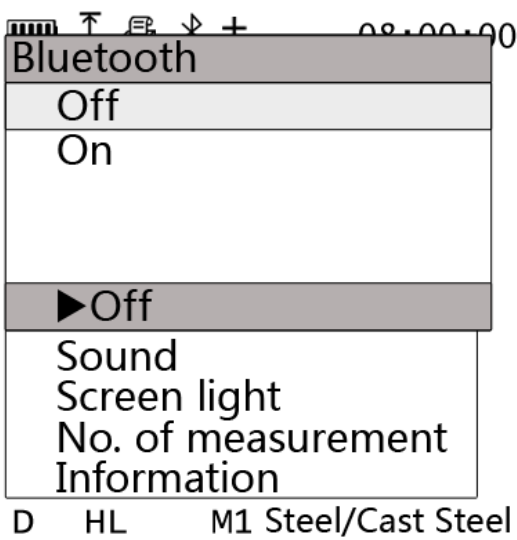
##### 2. Operation

	<p>Press ▲ or ▼ to move the option;          Press ● to confirm and exit;          Press and hold ● to confirm and return to Measurement screen.          Select On to enable Bluetooth port;          Select Off to disable Bluetooth port.</p>
Bluetooth	Key operation

3. Meaning of menu

Bluetooth port is set for connecting a Bluetooth printer or Android phone. Select Bluetooth → On, the icon  will appear in the status bar, indicating not connected to the printer or phone. When icon  display, indicating connected to the printer or phone.

1.19.6.Sound

1. Entry

Press ▲ in Measurement screen to enter Configuration Menu screen. Press ▲ or ▼ to select Sound, and press ● to enter Sound screen.

2. Operation

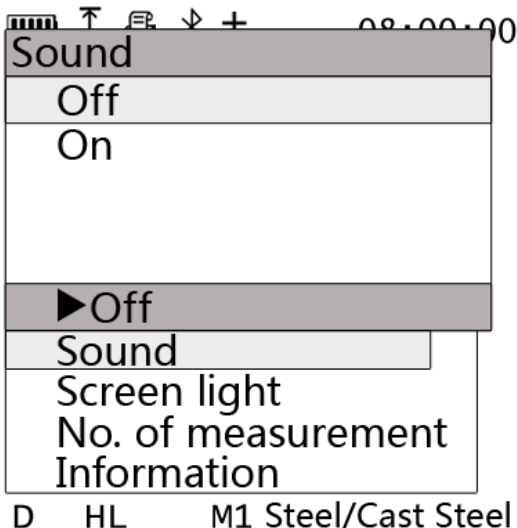
	<p>Press ▲ or ▼ to move the option;          Press ● to confirm and exit;          Press and hold ● to confirm and return to Measurement screen.          Select On to enable Sound;          Select Off to disable Sound.</p>
Sound	Key operation

3. Meaning of menu

Sound is set for reminder. The buzzer emits "dripping" sound during measurement or during parameter setting. If the user does not need Sound, you can Off it.

Note

When the Sound is Off, after enabling 1.20.5 Limit/Deviation, Sound is enabled automatically.

### 1.19.7. Screen Light

#### 1. Entry

Press ▲ in Measurement screen to enter Configuration Menu screen. Press ▲ or ▼ to select Screen Light, and press ● to enter Screen Light screen.

#### 2. Operation

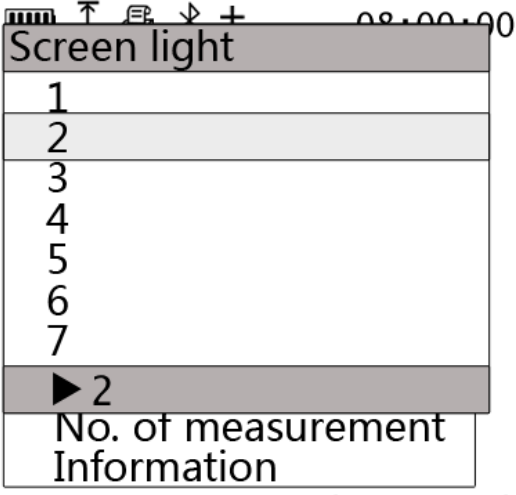
	<p>Press ▲ or ▼ to move the option;          Press ● to confirm and exit;          Press and hold ● to confirm and return to Measurement screen.          1-7 is the level of the screen light. The screen light changes immediately after selecting.</p>
Screen Light	Key operation

#### 3. Meaning of menu

Choose different screen light according to the brightness of the ambient light. As the environment is dark, you can choose level 1-3 light to protect eye and save power; as the environment is bright, you can choose level 4-7 light for bright display.

<p>Note</p> <p>The brighter the light, the more power the instrument consumes and the shorter the battery life.</p>
---

### 1.19.8. No. of Measurement

#### 1. Entry

Press ▲ in Measurement screen to enter Configuration Menu screen. Press ▲ or ▼ to select No. of Measurement, and press ● to enter No. of Measurement screen.

#### 2. Operation

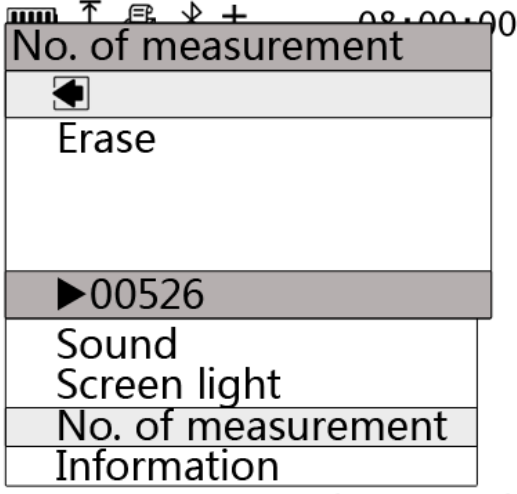

	<p>Press ▲ or ▼ to move the option;          Press ● to confirm and exit;          Press and hold ● to confirm and return to Measurement screen.          Press Erase to clear the number of measurements. A window will appear for confirmation. Press (and hold) ● to delete, displaying ✓ after deleting successfully and return to Measurement screen; Press other key to cancel the operation.          Press [Enter] to exit or return to the Measurement screen.</p>
No. of Measurement	Key operation

### 3. Meaning of menu

This function can be used to count the number of measurements, so that the users can maintain the Impact based on it.

#### 1.19.9. Information

##### 1. Entry

Press ▲ in Measurement screen to enter Configuration Menu screen. Press ▲ or ▼ to select Information, and press ● to enter Information screen.

##### 2. Operation

	<p>Press ● to exit;          Press and hold ● to return to Measurement screen.</p>
Information	Key operation

	<p>In Information screen:          Press ▲ or ▼ display the QR code;          Press ● to return to Instrument Information screen.          Press and hold ● to return to Measurement screen.</p>
QR code	Key operation

### 3. Meaning of menu

Information contains the program version, machine serial number, patent number (not all), applicable standards (not all) and other information, conducive to product identification, standard management, after-sales service etc. Scan the QR code of smart phones to read the color instrument promotion information.

## 1.20. Menu

### 1. Entry

Press ▼ in Measurement screen to enter Menu screen.

### 2. Operation

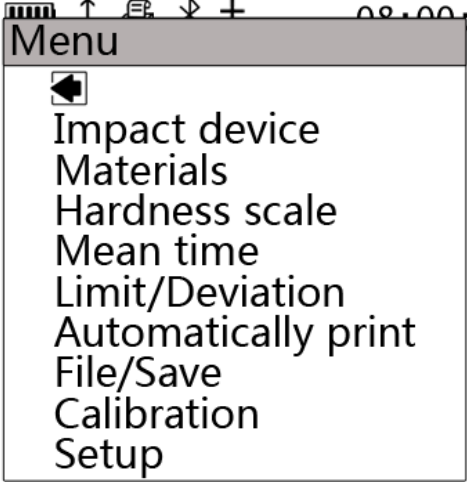
	<p>Press ▲ or ▼ to move the option;          Press ● to enter the option;          Press and hold ● to return to Measurement screen.          Press ☐ to exit.</p>
Menu	Key operation

### 3. Meaning of menu

There are 9 options, which are mainly used to for setting of test. For example, you can set the Impact Device, Select Material, Hardness Scale and so on.

## 1.20.1. Impact Device

### 1. Entry

Press ▼ in Measurement screen to enter Menu screen. Press ▲ or ▼ to select Impact Device, and press ● to enter Impact Device screen.

### 2. Operation

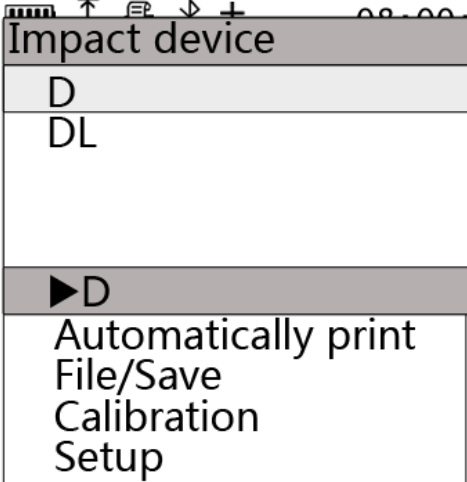
	<p>Press ▲ or ▼ to move the option;          Press ● to confirm and exit;          Press and hold ● to confirm and return to Measurement screen.          D and DL are the Impact Device.</p>
---	---

Impact Device	Key operation
---------------	---------------

3. Meaning of menu

This option is to set the impact device. Select the proper impact device to ensure the correct reading.

1.20.2. Materials

1. Entry

Press ▼ in Measurement screen to enter Menu screen. Press ▲ or ▼ to choose Materials, and press ● to enter Materials screen.

2. Operation

	<p>Press ▲ or ▼ to move the option;          Press ● to confirm and exit;          Press and hold ● to confirm and return to Measurement screen.          M1- M12 are the type of materials under test.</p>
Materials	Key operation

3. Meaning of menu

Select the proper material under test to ensure the correct reading.

1.20.3. Hardness Scale

1. Entry

Press ▼ in Measurement screen to enter Menu screen. Press ▲ or ▼ to select Hardness Scale and press ● to enter Hardness Scale screen.

2. Operation

	<p>Press ▲ or ▼ to move the option;          Press ● to confirm and exit;          Press and hold ● to confirm and return to Measurement screen.          HL, HRC and others are scales for the hardness.</p>
Hardness Scale	Key operation

3. Meaning of menu

Select the proper hardness scale to ensure the correct reading.

<p style="text-align: center;">Note</p> <p>For some specific materials, not all hardness scales can be converted to each other. For scales of hardness which cannot be converted, there will be a "*" symbol. In case it is converted forcedly, the instrument will prompt . This icon indicates that the instrument needs to be upgraded to provide this function. "*" is not described below in this manual.</p>
--

1.20.4. Mean Time

1. Entry

Press ▼ in Measurement screen to enter Menu screen. Press ▲ or ▼ to select Mean Time, and press ● to enter Mean Time screen.

2. Operation

	<p>Press ▲ or ▼ to move the option;          Press ● to confirm and exit;          Press and hold ● to confirm and return to Measurement screen.          Select 3, 4, 5, 6 or 7 as the mean time;          The option Close means no average calculation is required.</p>
Mean Time	Key operation

3. MEANING OF MENU

After setting the mean time, each time the cumulative number of measurements reaches the setting, the average number will automatically display in Display Style 1-3.

### 1.20.5. Limit/Deviation

#### 1. Entry

Press  $\blacktriangledown$  in Measurement screen to enter Menu screen. Press  $\blacktriangle$  or  $\blacktriangledown$  to select Limit/Deviation, and press  $\bullet$  to enter Limit/Deviation screen.

#### 2. Operation

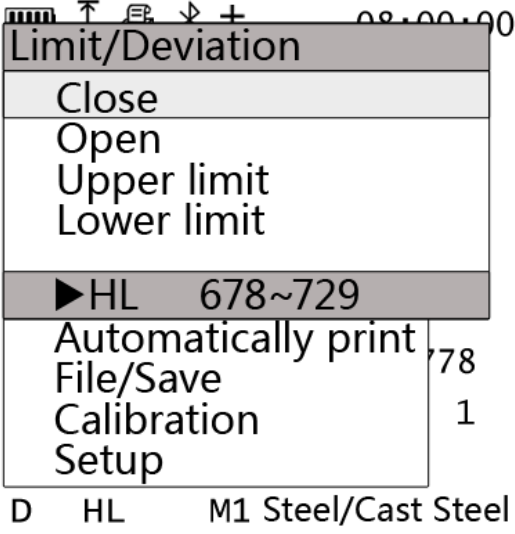
	<p>Press <math>\blacktriangle</math> or <math>\blacktriangledown</math> to move the option;          Press <math>\bullet</math> to confirm and exit, or enter Upper/Lower Limit adjustment;          Press and hold <math>\bullet</math> to confirm and return to Measurement screen, or enter Upper/Lower Limits adjustment.          Close: Close Limit/Deviation alarm;          Open: Open Limit/Deviation alarm;          When Upper/Lower Limit is selected in the Configuration Menu, displaying:          Upper Limit: enter Upper Limit adjustment          Lower Limit: enter Lower Limit adjustment.          When Deviation is selected in the Configuration Menu, displaying:          Evaluation Value: enter evaluation value adjustment;          Deviation: enter the deviation adjustment.</p>
Limit/Deviation	Key operation

#### 3. Meaning of menu

Select Enable Upper/Lower Limit, the sound is automatically on. The icon  $\updownarrow$  displays in status bar in the Measurement screen. During measuring, if the limit is overrun, "drip" will sound for three times. If the measurement is greater than the upper limit,  $\blacktriangle$  or  $\up$  displays next to the measurement; If the measurement is less than the lower limit,  $\blacktriangledown$  or  $\downarrow$  displays next to the measurement. Under Display Style 4, if the value exceeds the Limit/Deviation, the display is in red. When Evaluation Mode  $\rightarrow$  Upper/Lower Limit is selected in the Configuration Menu, select Limit/Deviation in the Menu to adjust the upper limit or lower limit. When Evaluation Mode  $\rightarrow$  Deviation is selected in the Configuration Menu, select Limit/Deviation in the Menu to adjust the evaluation value or the deviation.

Select Open to open the Limit/Deviation prompt.

Select close to close the Limit/Deviation prompt.

After disabling the Limit/Deviation alarm, turn off the sound in Configuration Menu.

During data statistics, the data over the range is processed as non-compliance data.

#### Note

For the selection of Limit/Deviation, see 1.19.4 Evaluation Mode.

### 5.1.1.4. Upper/Lower Limit

#### 1. Entry

Press  $\blacktriangledown$  in Measurement screen to enter Menu screen. Press  $\blacktriangle$  or  $\blacktriangledown$  to select Limit/Deviation, and press  $\bullet$  to enter Limit/Deviation screen.

Press ▲ or ▼ in Limit/Deviation screen to select Upper Limit or Lower Limit, and press ● to enter Upper Limit or Lower Limit screen.

2. Operation

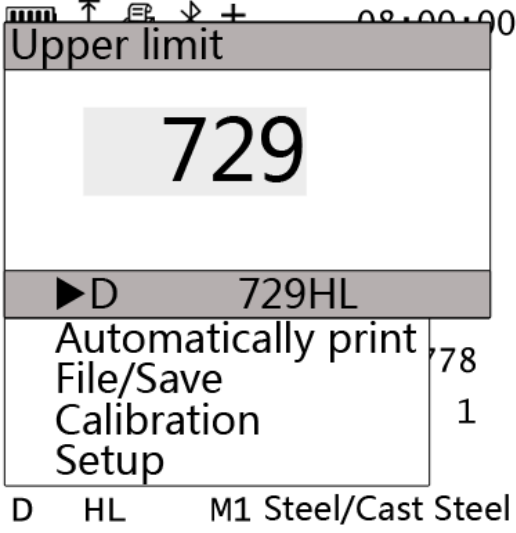
	<p>Press ▲ or ▼ to change the upper/lower finely (step 1 for Leeb's value);          Press and hold ▲ or ▼ to change the upper/lower coarsely (step 10 for Leeb's value);          Press (and hold) ● to confirm and exit.</p>
Upper Limit	Key operation

5.1.1.5. Evaluation Value/Deviation

1. Entry

Press ▼ in Measurement screen to enter Menu screen. Press ▲ or ▼ to select Limit/Deviation, and press ● to enter Limit/Deviation screen.

Press ▲ or ▼ in Limit/Deviation screen to select Evaluation Value or Deviation, and press ● to enter Evaluation Value or Deviation screen.

2. Operation

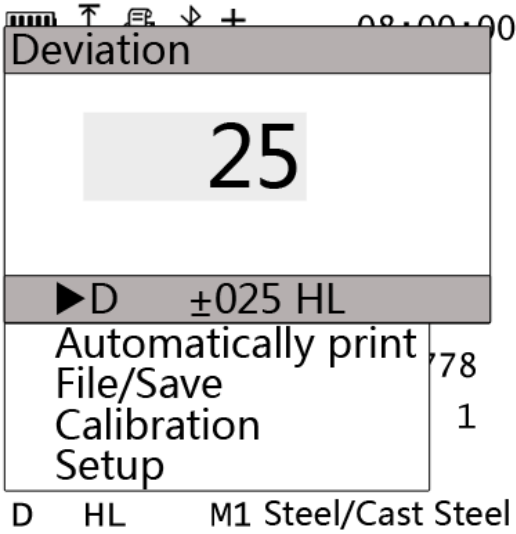
	<p>Press ▲ or ▼ to change the upper/lower finely (step 1 for Leeb's value);          Press and hold ▲ or ▼ to change the upper/lower coarsely (step 10 for Leeb's value);          Press (and hold) ● to confirm and exit.</p>
Deviation	Key operation

1.20.6. Automatically Print

1. Entry

Press ▼ in Measurement screen to enter Menu screen. Press ▲ or ▼ to select Automatically Print, and press ● to enter Automatically Print screen.

## 2. Operation

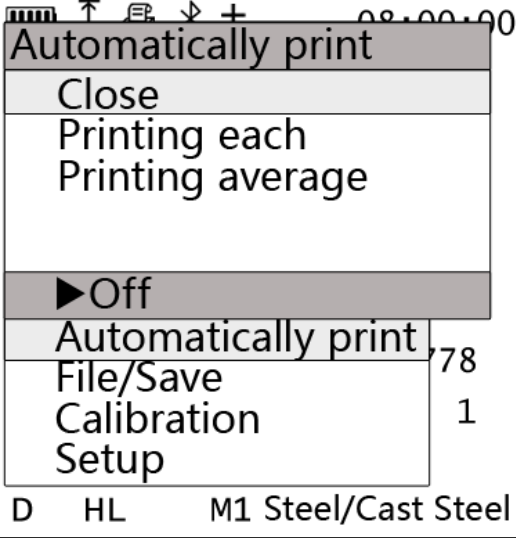
	<p>Press ▲ or ▼ to move the option;          Press ● to confirm and exit;          Press and hold ● to confirm and return to Measurement screen.          Select Printing Each Measurement to enable printing of each test result;          Select Printing Average to enable printing of the average;          Select Close to close Automatically Print.</p>
Automatically Print	Key operation

## 3. Meaning of menu

Automatically Print is valid only for special Bluetooth printers. When Automatically Print is enabled, the icon  will be displayed in the status bar. The Bluetooth port is set in the Configuration Menu. See 1.19.5 Bluetooth.

Select Printing Each Measurement to print each measurement in real time. The average is printed only after Mean time is selected and the average appears.

### Note

As Automatically Print is enabled but no printer is connected, Model 4100 can still work. However, Model 4100 will look for the printer continuously, which will seriously reducing the efficiency and wasting more battery power. For this reason, Model 4100 will automatically turns off Automatically Print when multiple prints failed.

## 1.20.7. File / Save

### 5.1.1.6. Save

#### 1. Entry

Press ▼ in Measurement screen to enter Menu screen. Press ▲ or ▼ to select File / Save, and press ● to enter File / Save screen.

#### 2. Operation

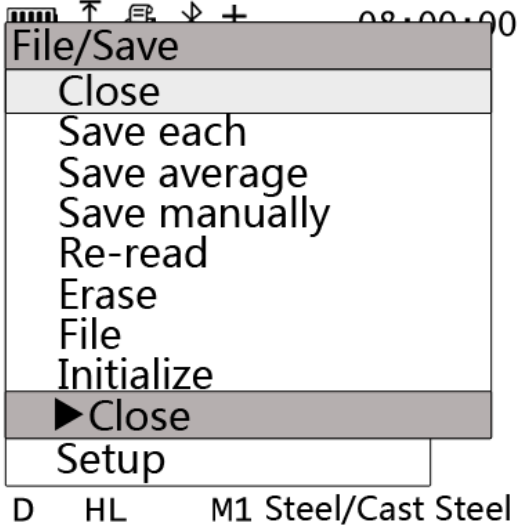
	<p>Press ▲ or ▼ to move the option;          Press ● to confirm and exit;          Press and hold ● to confirm and return to Measurement screen.          Save Each Measurement, Save average, Save manually are three kinds of storage; As Save manually is selected, press ● to save the current value after the value is displayed.          Select Close to close the storage function;          Select File to change the current stored file;          Select Erase to delete the data in the current file;          Select Initialize to delete data in all files.</p>
File / Save	Key operation

3. Meaning of menu

Model 4100 provide three kinds of storage methods. Select Save each Measurement, each measurement is saved. As Save average is chosen, only as Mean time is enabled, the final average is saved after the average number is complete. As Manual Save is chosen, the operator needs to choose whether to save.

**5.1.1.7. Re-read**

1. Entry

Press ▼ in Measurement screen to enter Menu screen. Press ▲ or ▼ to select File / Save, and press ● to enter File / Save screen.

Press ▲ or ▼ in File / Save screen to select Re-read, and press ● to enter Re-read screen.

2. Operation

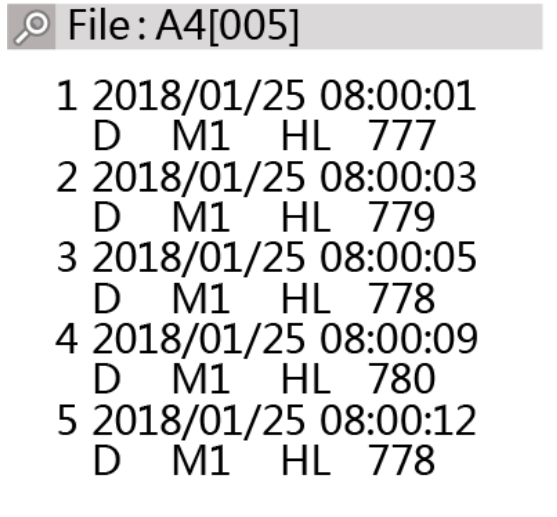
	<p>Press ▲ or ▼ for Page Up/Page Down;          Press and hold ● to move the cursor to the file name, then press ▲ or ▼ to change the folder. At last press and hold ● to confirm the folder;          Press ● to exit.</p>
Re-read	Key operation

3. Meaning of menu

You can view the data in the folder as well as the identification information related to the data.



### 5.1.1.8. Erase/Initialize

Select Erase to delete the data in the current file. Select Initialize to delete data in all files. The deleted data cannot be restored.

#### 1. Entry

Press ▼ in Measurement screen to enter Menu screen. Press ▲ or ▼ to select File / Save, and press ● to enter File / Save screen. Press ▲ or ▼ to select Erase or Initialize.

#### 2. Operation

	<p>Confirm again before executing Erase or Initialize. Do you want to continue? Yes: continue the operation; No: cancel the operation.</p>
Erase all	Key operation

#### 3. Meaning of menu

Delete the data in the specified file to save new data. If you want to delete the data in all files, select Initialize.

### 5.1.1.9. File

#### 1. Entry

Press ▼ in Measurement screen to enter Menu screen. Press ▲ or ▼ to select File, and press ● to enter File screen.

#### 2. Operation

	<p>Press ▲ or ▼ to change the file No.; Press (and hold) ● to confirm and exit after displaying √.</p>
File	Key operation

Note

There are total 31, 63 or 250 file numbers (depending on the type of instrument memory chip. Note in the order).

3. Meaning of menu

Change the file No. to specify the current file to store the data.

1.20.8. Calibration

This menu is used to Open/Close calibration and to enter calibration adjustments.

1. Entry

Press ▼ in Measurement screen to enter Menu screen. Press ▲ or ▼ to select Calibration, and press ● to enter Calibration screen.

2. Operation

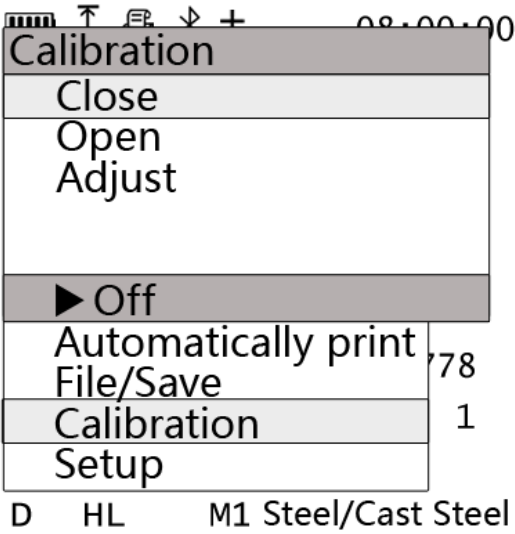
	<p>Press ▲ or ▼ to move the option;          Press ● to confirm and exit, or enter the calibration Adjust screen;          Press and hold ● to confirm and return to Measurement screen, or enter the calibration Adjust screen.          Press Close to enable calibration;          Press Open to disable calibration;          Press Adjust to enter the Adjustment screen.</p>
<p>Calibration</p>	<p>Key operation</p>

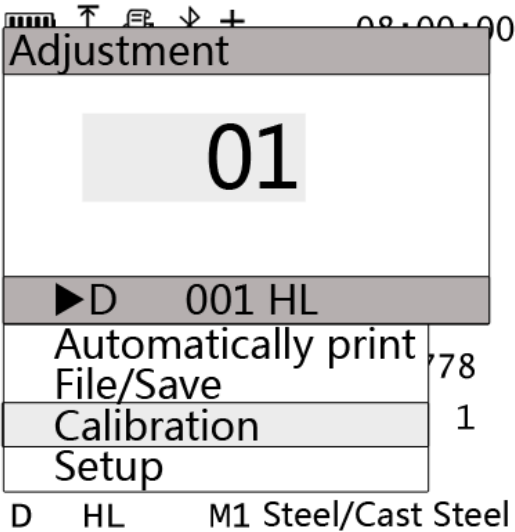
	<p>Press ▲ or ▼ to change the adjustment finely (step 1 for HL);          Press and hold ▲ or ▼ to change the adjustment coarsely (step 10 for HL);          Press (and hold) ● to confirm and exit.</p>
<p>Adjustment</p>	<p>Key operation</p>

Note

When the adjustment is 0, the Calibration function is not enabled.

Adjustment = Nominal value of standard test block - measurement of standard test block.

3. Meaning of menu







The Impact may be worn after use multiple times and the measurement may be inaccurate and usually higher. Calibration is required for regular maintenance and calibration of the instrument. If Calibration is Open, the icon  will display in the status bar when Model 4100 is powered on.

1.20.9. Setup

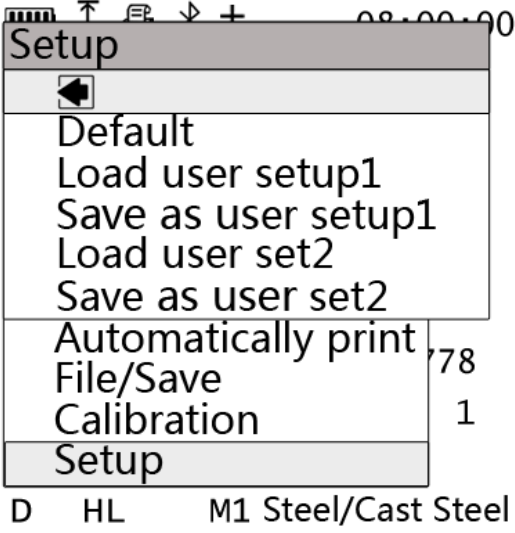
1. Entry

Press  in Measurement screen to enter Menu screen. Press  or  to select Setup, and press  to enter Setup screen.

2. Operation

	<p>Press  or  to move the option;                  Press  to confirm;                  Press and hold  to return to Measurement screen.                  Select Default to use the default parameters.                  Select Load User Setup to use the user-saved parameters;                  Select Save as User Setup to save the current settings as the user's settings.                  Press  to exit.</p>
Setup	Key operation

3. Meaning of menu





For convenient setting of the instrument. Select Save as User Setup to save the current job number, serial number etc. for the user. Select Load User Setup to load the user-saved parameters to the instrument;

## 1.21. Shortcuts

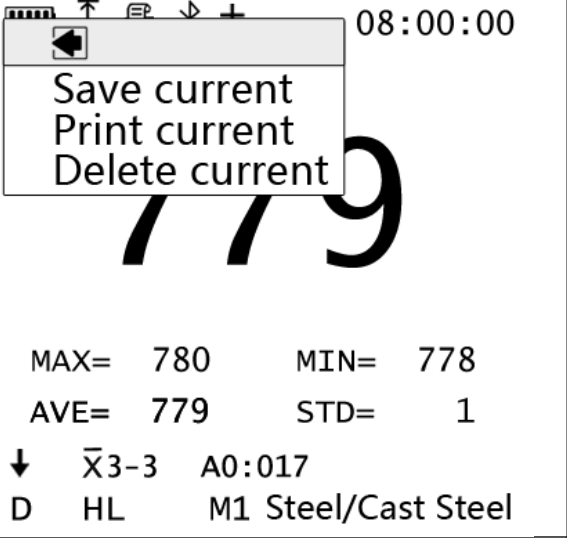

### 1. Entry

Press  in Measurement screen to enter Shortcuts screen.

### 2. Operation

 <p>08:00:00</p> <p>Save current Print current Delete current</p> <p>779</p> <p>MAX= 780      MIN= 778 AVE= 779      STD= 1</p> <p>↓ <math>\bar{X}</math>3-3    A0:017 D HL      M1 Steel/Cast Steel</p>	<p>Press  or  to move the option; Press  to confirm and exit;</p>
Shortcuts	Key operation

### 3. Meaning of menu

As Menu -> File / Save -> Save Manually is selected, the value is saved manually. To save the measurement, choose Save Current Value, display:  after saving successfully; if the icon  is displayed, then space is full. You need to change the folder to store or delete data. If Save Each Measurement or Save Average is chosen, the operation of saving the current value is invalid at this time, displaying .

If the Print is enabled, to print the current measurement, for both Printing Each Measurement or Printing Average, the current value will be printed when you choose Print Current Value. If the Print is close, you cannot print the current value, displaying: .

If the test results are incorrect or you do not want to save the current test results, you can choose Delete Current Value to delete the last test data, displaying  after successful deletion.

## 6. Operation

### Note

This product does not have liquid, dust, drop and other protection. Be careful during operation. SADT does not provide free warranty service due to damage to the instrument caused by liquid, dust, drop etc.

The LCD display protection is limited. Avoid sharp knife scratches or bumping. Do not clean it with organic solvents (alcohol, gasoline, etc.). SADT does not provide free warranty service for LCD scratches, damage, deformation, etc.

### 1.22. Start/Shutdown

#### 1.22.1. Preparation

Make sure before power on:

- (1) The battery is installed correctly;
- (2) The sensor is connected correctly;
- (3) The sample to be tested is prepared according to the requirements;

#### 1.22.2. Start

Press power ● to start.

After the instrument is powered on, the booting screen displays, containing the following contents:

Version Number and Version Date  
Machine Serial Number  
Current Date and Time  
Website URL  
Patent Number (Partially, Not All)  
Applicable Standards (Partially, Not All)

If Calibration is enabled, the icon  will display. Check and make sure the Adjustment is set correctly for correct measurement.

If the battery level is low, the icon  will display and the instrument shuts down.

After starting, the instrument enters the Measurement screen. Make sure correct parameters of the instrument and ensure that the instrument has qualified accuracy before the formal measurement. To change the settings, refer to Setting of Instrument.

#### 1.22.3. Shut down

##### 6.1.1.1. Manual Shutdown

Press and hold power ● to shut down.

### Note

To avoid wrong operation, Press and hold the key until the power is turned off, usually for more than 3 seconds.

### 6.1.1.2. Auto Shutdown

When there is no operation on Model 4100 and timing 110s, the instrument automatically shuts down. Press any key during the countdown to cancel the automatic shutdown.

### 1.23. Operation of Probe

- (1) The probe is sophisticated. Be careful during operation.
- (2) The probe is easy to wear. All parts will be worn to some degree with increased number of measurements. Using worn probes to measure hardness may reduce the accuracy of the measurement.
- (3) The wire of wired probes may bend. The wire connector is a vulnerable part. Avoid sharp bending or strong pulling, etc., which may reduce the lifetime of the wire and the connector.
- (4) Prevent oil, water, dust and others entering the probe.

#### 1.23.1. Load

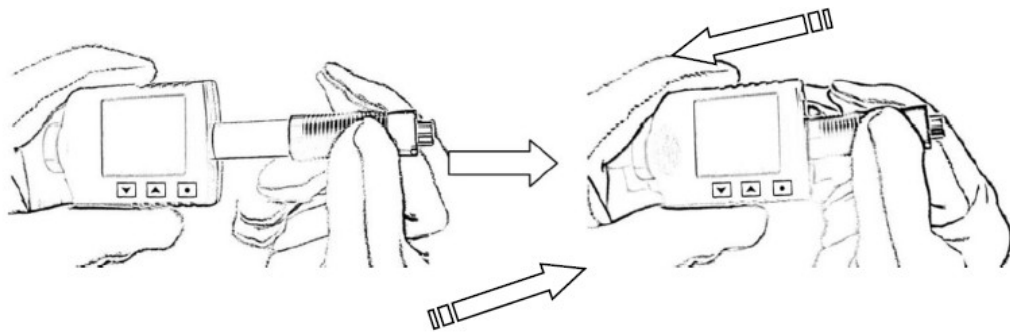

As shown in the figure, hold the body by left hand, hold the probe loading lever by right hand and push toward the body, until the spring is compressed to the end. Slowly release the right hand, so that the loading lever returns to its original position to complete the loading.

#### 1.23.2. Release (measurement)

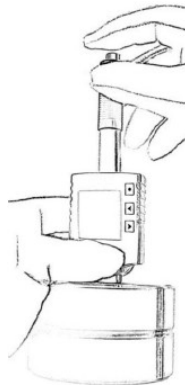

Hold the body by left hand and keep it perpendicular to the measured surface of the workpiece under test. Press the button on the top by right hand to release the impact. The hardness value will be displayed on the screen.

#### Note





To release the impact, be sure to keep the probe perpendicular to the workpiece surface. Slight tilt and jitter will affect the measurement accuracy.

In continuous operation, the interval between two measurements should not be less than 1 second.

## 1.24. Re-read, Save, Delete and Print Measurements

Model 4100 store the measurement in the form of Record. Each record includes the measuring time (Year/Month/Day/Min./Second), Impact device, Select Material, Hardness scale, Measurement, Overrun Flag and other fields. The records are stored in files. Each file can store 100 records.

### 1.24.1. Re-read of Measurements

Press  to enter Menu screen. Press  or  to select File / Save. Select View and press  to enter.

Press  or  for Page Up/Page Down;

Press and hold  to change the file name;

Press  to exit.

 File: A4[005]	
1 2018/01/25 08:00:01 D M1 HL 777	Numerical format:
2 2018/01/25 08:00:03 D M1 HL 779	Label Date Time
3 2018/01/25 08:00:05 D M1 HL 778	Probe Type Select Material Unit
4 2018/01/25 08:00:09 D M1 HL 780	Measurement Overrun Flag
5 2018/01/25 08:00:12 D M1 HL 778	

### 1.24.2. Save Measurement









When a storage error occurs (for example, the number of records in a file has reached the maximum number of 100), the icon  will be displayed.

For Save manually, if the same data is stored again, the icon  will be displayed.









#### 6.1.1.3. Save Average

Save Average needs to be set in two places:

##### 1. Set Mean time

Press  to enter Menu screen. Press  or  to select Mean time and press  to confirm. Press  or  to select "3 → 4 → 5 → 6 → 7" and press  to confirm. Press and hold  to return to Measurement screen.

##### 2. Set Save Average

Press  to enter Menu screen. Press  or  to select File / Save, and press  to enter. Press  or  to select Save average and press  to confirm. Press and hold  to return to Measurement screen.

In this way, during the measuring, the average value is saved every time it is displayed.

#### 6.1.1.4. Save Each Measurement

Press ▼ to enter Menu screen. Press ▲ or ▼ to select File / Save, and press ● to enter. Press ▲ or ▼ to select Save Each Measurement and press ● to confirm. Press and hold ● to return to Measurement screen.

In this way, during the measuring, each measurement is stored.

#### 6.1.1.5. Manual Save

Press ▼ to enter Menu screen. Press ▲ or ▼ to select File / Save and press ● to enter. Press ▲ or ▼ to select Save manually and press ● to confirm. Press and hold ● to return to Measurement screen.

In the Measurement screen, after each measurement, press ● to enter Shortcut Menu. Press ▲ or ▼ to Save Current Value and press ● to confirm. Display √ after being saved successfully. The measurement will not be saved if you do not press ● key.

In this way, during the measuring, you can manually decide whether to save the current measurement.

### 1.24.3. Delete Measurements

#### Note

The deleted records cannot be restored. Confirm whether to delete before deleting.

#### 6.1.1.6. Delete the Last Record

Press ● in the Measurement screen to enter Shortcut Menu. Press ▲ or ▼ to select Delete Current Measurement, the last record will be deleted, displaying  after successful deletion.

#### 6.1.1.7. Batch Delete Records

Batch Delete Records is set to delete all records in the current file. If you want to delete the records in all files, you can select Initialize. The deleted records cannot be restored. There are two entries for Batch Delete Records:

Press ▼ in the Measurement screen to enter Menu screen. Press ▲ or ▼ to select File / Save and press ● to enter File / Save screen.

Press ▲ or ▼ to select Erase or Initialize.

Confirm before executing Erase or Initialize. Select Yes to continue the operation. Select No to cancel the operation.

### 1.24.4. Print Measurements

Automatically Print and Manual Print are set for the measurements, and Print Each Measurement and Print Average are set for Auto Print. You can select Manual Print via 1.21 Shortcuts to print the current measurement.

Before printing, set the printer port correctly via 1.19.5 Bluetooth.



### 6.1.1.8. Automatically Print

Printing Each Measurement and Printing Average are set for Automatically Print. After Printing Each Measurement is chosen, each measurement is printed automatically after each measuring. After Printing Average is chosen, the average is printed automatically after reaching the average number.

See method for enable 1.20.6 Automatically Print.

In case Printing Each Measurement is enabled, load the scale, display the value. When the measurement displays on the screen, the printer will automatically print the measurement. In case Printing Average is enabled, the average, maximum, minimum, standard deviation, etc. will be printed after the mean time is reached, as shown below:



2016/09/04 10:02:25	Date Time
1: D M1 HL=874(+)	Label: Probe Type Material Unit = Measurement
2016/09/04 10:02:28	(+ Exceed Upper Limit, - Exceed Lower Limit, no sign
2: D M1 HL=787	indicates no overrun)
2016/09/04 10:02:31	.....
3: D M1 HL=789(+)	.....
AVE = 817	AVE = 817
MAX = 874	MAX = 874
MIN = 787	MIN = 787
STD = 049	STD = 049

### 6.1.1.9. Print Current Measurement

The current measurement can also be printed after selecting Print Current Measurement without Automatically Print enabled. The steps are as follows:

- (1) Press ● in the Measurement screen to enter Shortcut Menu;
- (2) Select Print Current Measurement and press ● to confirm. At the moment the printer will print the current measurement. You can repeat to for multiple printing.

## 1.25. Upload Measurement to Computer

### 1.25.1.Driver installation

Computer will prompt "Found new hardware" while the hardness tester is connected to the computer first time, please install the driver located in X:\Drivers folder. (X: means CDROM drive letter).

### 1.25.2.Software Installation

Double click "setup.exe" to install the PC software. Please follow the installation wizard to finish it.

### 1.25.3.Start PC software

After the data communication software is installed, a shortcut will be created on the desktop automatically. Double click the shortcut to run the program.

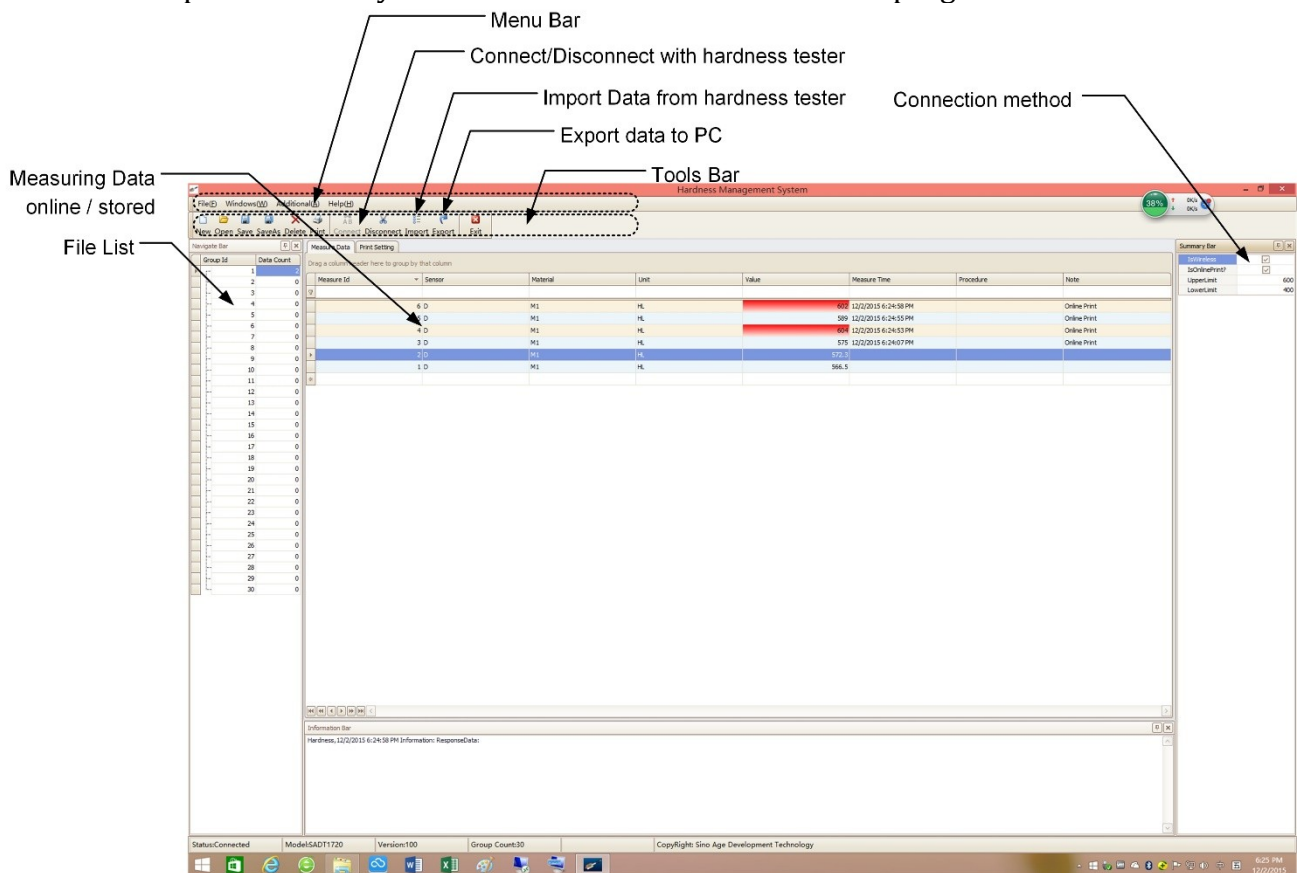

The main interface of the software is a standard windows form, containing the title bar, menu bar and toolbar.

**Please note: After running the software, click the "Connect" from the toolbar to create connection between PC and tester. If it is connected by Bluetooth, please click "IsWireless" option in the right Summary Bar first, then click "Connect" button to connect wireless connection. Bluetooth pairing code is 1234.**

## 7. Maintenance of Probe

### CAUTION

Do not open or remove the instrument and its fixed parts freely. The service of precision instruments should be provided by our professionals.

If the instrument or sensor or other accessories are disassembled, SADT no longer offers free warranty service and the warranty associated therewith becomes also invalid.

Avoid collision, liquid immersion, heavy dust, moisture, oil or strong magnetic field.

After using up to 500-2000 times, clean the guide tube and the impact body with the accompanying brush in the following procedure.

Unscrew the support ring and remove the impact body.

Turn the brush counterclockwise into the bottom of the guide tube and pull it out again.

Repeat 5-6 times to clean the guide tube.

Replace the impact body and the support ring.

After each test, release the impact spring.

Do not use any kind of lubricant!

When calibrating the hardness tester with a standard test block, reading above 1 HRC indicates that the impact ball is worn and needs to be replaced.

In case of any problem not mentioned, please contact us.

### Note

Probe is wearing part. With the number of use increases, all parts of the probe will be worn to different degree, and the measurement accuracy will decline. In case the measurement accuracy cannot reach the standard, replace it with a new one. To ensure the accuracy, calibrate the instrument after the replacement. Contact us for calibration.

## 8. Accessories

### 1.26. Thermal Printer

#### 1.26.1. Precautions

##### 1. Select proper printer model

There is variety of printers available on the market, and their protocols and ports are different. Model 4100 is not designed for all printers on the market. The users shall contact the dealer to select the correct printer model.

##### 2. Operate the printer correctly to avoid damage.

(1) In the event of paper jam, turn off the power, wait 10 seconds for the head to cool down, and then remove the jammed paper.

(2) Do not place this product in humid or dusty environment. No stress or stack.

(3) Use qualified paper (with roll).

(4) Do not use paper with end sticking to the roll, otherwise the printer will not identify the end of the paper or may cause damage to the printer.

(5) Do not print for long time.

(6) If no paper is installed, the printer may be damaged.

#### 1.26.2. List of Parts of Printer

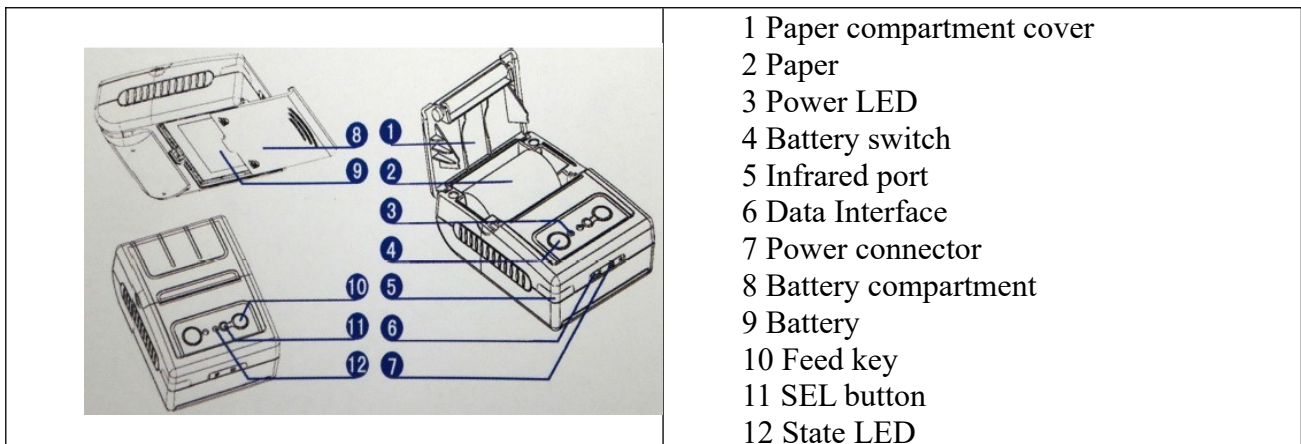

#### 1.26.3. Operation

##### 1. Installation:

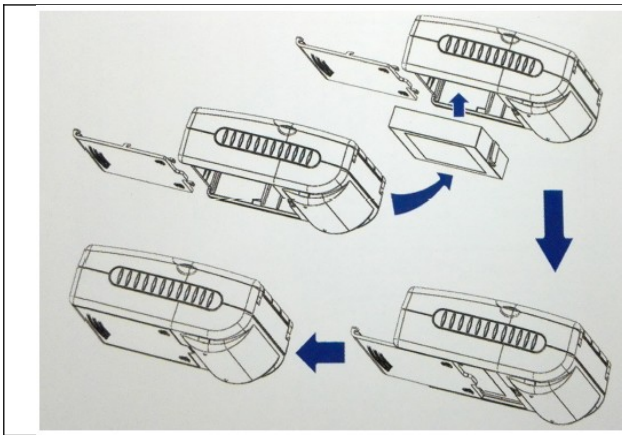

As shown in the figure, push and open the battery cover. Push the bottom clip of the battery into the printer. Mount the other end. Push the battery cover back.

2. Power on: Press and hold the power switch (left on the panel) for about 3 seconds, the power is on. The Work LED light (the power will not be on if the button is pressed for less than 3 seconds).
3. Shutdown: In working state, press and hold the power switch (left on the panel) for about 3 seconds, the power is off. The Work LED goes out (the power will not be off if the button is pressed for less than 3 seconds).

#### 4. Connection:

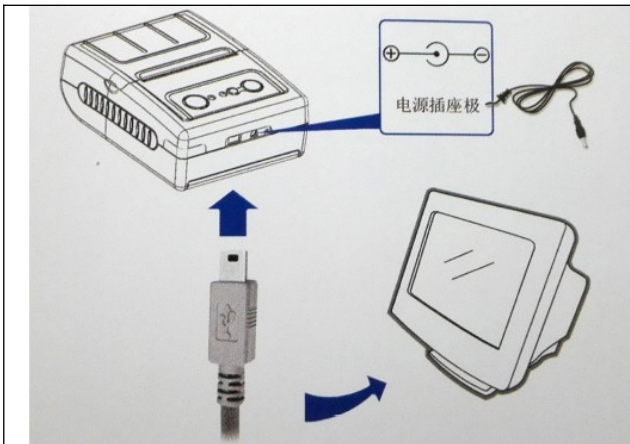

- (1) Communication:  
Bluetooth port: After turning on, the printer will automatically connect with hardness tester. No other operation is required.
- (2) Power connection:  
The portable miniature printer is powered by rechargeable battery.

5. Feed paper: Press the Feed Paper button (right on the panel) to feed paper. Release the button to stop feeding.

#### 6. Load paper:

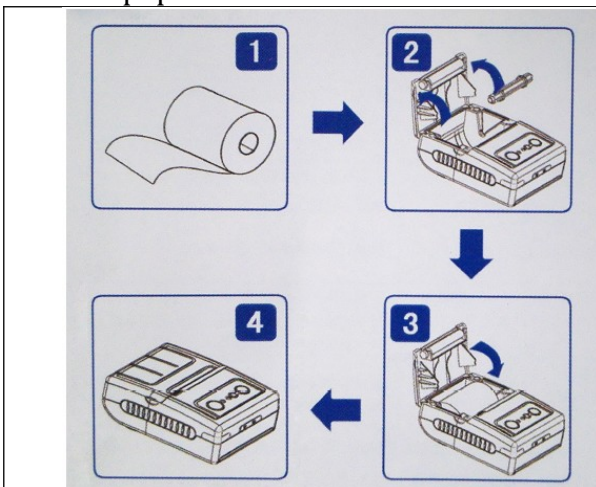

- (1) Open the compartment cover as shown in Figure 2 in the direction of the arrow.
- (2) Mount the paper and pull it out. Keep the paper in order and in correct direction. The face with liquid (smooth) is downward.
- (3) Close the cover. Press the paper roll into the head after it is aligned with the printer.
- (4) Turn on. Press Feed Paper to make the head rotate. If the paper is not going in straight, press Feed Paper again.
- (5) Size of paper: 57 \* 50mm (width \* diameter)

7. Self-test: Press the Feed Paper button (right on the panel) in power off state and then turn on the power. Self-test of printer starts.

## 8. Cleaning:

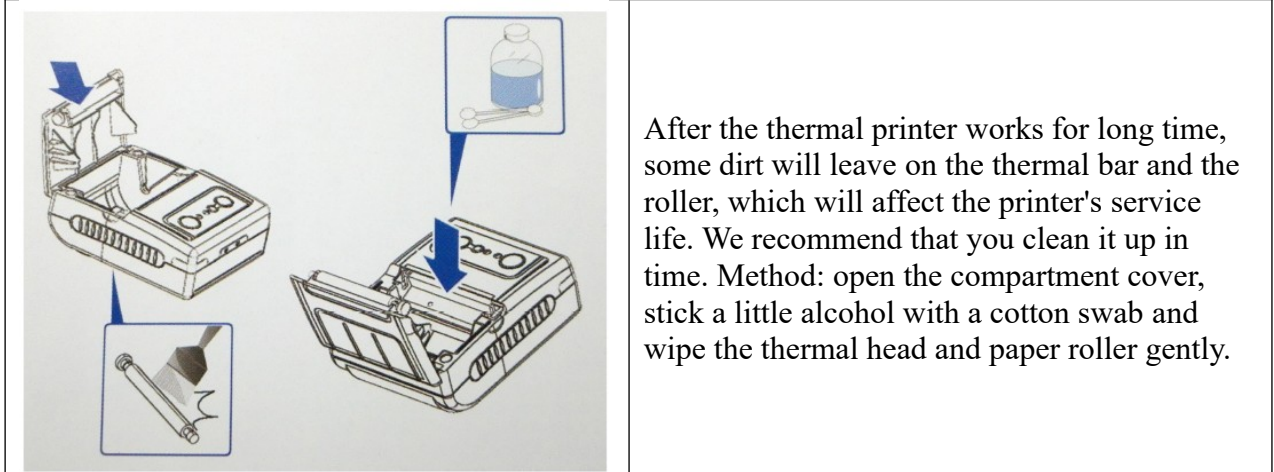

### 1.26.4.State LED

#### 1. Working LED

In case Print head is overheated, out of paper, the printer compartment cover is open: Working LED flashes in 4 seconds cycle (on for 2 seconds and off 2 seconds);

#### 2. Communication LED

When the printer is in Standby mode, the Communication LED flashes in 2 seconds cycle (on for 50 ms);

#### 3. Power LED

(1) During working of the printer, when the battery level is more than 50%, the Power LED (green) is On;

(2) When the battery level is 50% ~ 30%, the Power LED (yellow) is On;

(3) When the battery level is less than 30%, the Power LED (red) is On;

(4) When the battery level is too, the printer will automatically shut down;







(5) During charging, the charger LED (red) is On.

(6) After charging is completed, the LED (green) is On.

### 1.27. Shaped Support Ring

In order to meet the requirements of different measuring surface, we provide the following special-shaped support rings.



Picture	Model	Size	Size of applicable measurement surface	Name of applicable measurement surface
	D6	$\Phi 9.5 \times 5.5 \text{mm}$	$R \geq 60 \text{mm}$	Plane, cylinder, concave cylinder, spherical, concave spherical
	D6a	$\Phi 3.5 \times 5.5 \text{mm}$	$R \geq 30 \text{mm}$	Plane, cylinder, concave cylinder, Spherical, concave spherical
	Z 10-15 Z 14.5-30 Z 25-50	$\Phi 20 \times 20 \times 7.5 \text{mm}$ $\Phi 20 \times 20 \times 6.5 \text{mm}$ $\Phi 20 \times 20 \times 6.5 \text{mm}$	R 10mm-15mm R 14.5mm-30mm R 25mm-50mm R < 10mm Unable to measure $R \geq 30 \text{mm}$ D6/D6a	Cylinder
	HZ 11-13 HZ 12.5-17 HZ 16.5-30	$\Phi 20 \times 18 \times 5 \text{mm}$ $\Phi 20 \times 20 \times 5 \text{mm}$ $\Phi 20 \times 20 \times 5 \text{mm}$	R 11mm-13mm R 12.5mm-17mm R 16.5mm-30mm R < 11mm Unable to measure $R \geq 30 \text{mm}$ D6a	Concave cylinder
	K 10-15 K 14.5-30	$\Phi 20 \times 7.7 \text{mm}$ $\Phi 20 \times 6.7 \text{mm}$	R 10mm-13mm R 14.5mm-30mm R < 10mm Unable to measure $R \geq 30 \text{mm}$ D6/D6a	Sphere
	HK 11-13 HK 12.5-17 HK 16.5-30	$\Phi 17 \times 5 \text{mm}$ $\Phi 18 \times 5 \text{mm}$ $\Phi 20 \times 5 \text{mm}$	R 11mm-13mm R 12.5mm-17mm R 16.5mm-30mm R < 11mm Unable to measure $R \geq 30 \text{mm}$ D6a	Concave spherical
	UN	$\Phi 52 \times 20 \times 16 \text{mm}$	----	Universal profiled surface

## 9. Calibration of Instrument

The purpose for calibration of Model 4100 is to ensure the accuracy of the instrument. In ideal state, if a standard test block is measured, the actual measurement should be equal to its nominal value. However, as the impact ball head is worn, the relationship will change. After the number of measurements reaches about 1000-5000 (depending on the specific measurement situation), the measurement accuracy may decline. The actual measurement is higher than the nominal value of the standard test block. The user shall calibrate the instrument in time.

Recommend: Calibrate the hardness tester using the standard test block every day before measuring. Only correct hardness testers can be used for formal measure. After the formal measure is completed, re-measure the hardness tester with a standard test block to ensure the reliability of the formal measurement.

### 1.28. Calibration Applications

When the hardness of the measured object is similar to that of the standard test block, calibration can be carried out.

There are two calibration modes: Coincident Mode and Independent Mode.

### 1.29. Setting of Calibration

#### 1.29.1. Setting of Coincident Mode

When Coincident Mode is selected for calibration of Leeb hardness, the data of other units will change following the calibrated Leeb hardness data.

Steps:

- (1) Select Leeb scale
- (2) Test using a standard block similar to the actual measurement. Record the difference between the actual measurement and the nominal value of the standard test block.
- (3) Press ▲ in Measurement screen to enter Configuration Menu screen. Press ▲ or ▼ to select Calibration Mode and press ● to confirm.
- (4) Press ▲ or ▼ to select Coincident and press ● to confirm.
- (5) Press ▼ to enter Menu screen. Press ▲ or ▼ to select Measurement Calibration and press ● to confirm.
- (6) Enter the calibration adjustment value. Adjustment value = nominal value of standard test block - measurement of standard block.

#### 1.29.2. Independent calibration settings

When Independent Mode is selected, only the hardness value of the selected scale is calibrated, and the hardness values of other scales do not change. For example, after HRC is calibrated, the value of HRB is not calibrated, and the measurement of HRB may be not accurate.

Operation: Similar to Coincident Mode. Just change the Calibration Mode to Independent Mode.



## 10. Q&A

### 1.30. About Configuration Menu

1. Why the sound is turned off, but turned on after the Upper/Lower limit is enabled?

A: After setting the Upper/Lower limit, once the measurement exceeds the range, Model 4100 display will give prompt. To prompt the operator, Model 4100 automatically activates the audible alarm. Therefore, even if the sound is turned off, as long as the Upper/Lower Limit is enabled, Model 4100 automatically turns on the sound.

2. Why cannot calibrate after selecting Independent Mode or Coincident Mode?

A: In the Configuration Menu, the selected Independent Mode or Coincident Mode is just one of the calibration modes. To enable the calibration, re-enable the Calibration in the Menu and ensure that the calibration adjustment is not zero.

### 1.31. About Menu

1. Why the hardness scale is marked with \* in front and cannot be chosen?

A: The hardness scale is marked with \* in two cases: one, the hardness of the scale is of value-added service, and standard Model 4100 does not provide. The user shall contact the seller before the purchase if they need; the other is that there is no data with this scale. To measure special materials, note in the order.

2. After setting the upper /lower limit, why  displayed?

A: The Upper/Lower Limit is set, Model 4100 will automatically check the Upper/Lower Limit. If the upper limit  $\leq$  lower limit, the icon  displays when exit the Upper/Lower Limit.

3. Why Measurement Calibration is enabled but no icon  display?

A: The prerequisite for enabling Measurement Calibration is to set the adjustment value in Adjustment menu in Measurement Calibration. Only as the Adjustment value is not 0, click Open to enable Calibration. If the Adjustment value is set to 0, meaning no adjustment, at this moment Calibration cannot be enabled.

### 1.32. About Wireless Applications

1. Can multi Model 4100 share a Bluetooth printer?

A: Cannot. Bluetooth communication needs to be paired. Once the pairing is completed, the Bluetooth printer communicates one-on-one with the paired Model 4100 successfully. Other Model 4100 cannot communicate with this Bluetooth printer, that is, multi Model 4100 cannot share a Bluetooth printer.

2. What is the communication distance between Model 4100 and Bluetooth printer?

A: The communication distance between Model 4100 and Bluetooth printer is about 5m.

3. Bluetooth of Model 4100 can communicate with the computer?

A: The Bluetooth of Model 4100 can communicate with the computer. Check whether your computer supports the Bluetooth serial protocol (SPP protocol). Some computer's Bluetooth adapter does not support the protocol. Bluetooth of Model 4100 is the slave mode with pairing password 1234.

4. Model 4100 can use WIFI communication?

A: Model 4100 does not support WIFI communication at present.

### **1.33. About USB Communication**

1. To connect the computer through USB of Model 4100, whether to install the USB driver?

A: Install. Model 4100 USB port is achieved using CH340 chip, supporting Windows XP, Windows 7, Windows 8, Windows 10 32-bit and 64-bit operating systems. The method of installing the driver varies with the operating system. For specific installation, refer to the relevant documents.

2. Can Model 4100 connect directly to the USB printer?

A: The Model 4100 is a USB slave device (slave USB) that can only be connected to a USB host device (master USB) and cannot directly connect to other USB slave devices, including a USB slave printer.

3. Why Model 4100 restarts frequently after connected with PC's USB port?

A: Every time the PC recognizes the USB system, Model 4100 will restart, which is normal. For example, when a USB is inserted, the Windows system detects the newly inserted USB device. At this moment, Model 4100 connected to the USB screen is also detected, causing Model 4100 to restart.

### **1.34. About Measurements**

1. When measuring the hardness of alloy tool steel with Model 4100, it shows that the Leeb hardness is 800 and the Brinell hardness is 711. Why is Brinell hardness so high?

A: Model 4100 is the Leeb hardness tester, you can directly measure the Leeb hardness data of sample. The hardness data of other units is obtained by conversion of the Leeb hardness measurement. Model 4100 can guarantee the accuracy of conversion data in the standard range. For conversion data beyond the standard range, although Model 4100 can display part of the conversion data for reference, but cannot guarantee its accuracy or significance.

The Leeb hardness of alloy tool steel is 800, indicating that the material is very hard metal. For such hard metal, Brinell hardness measurement is not available. Therefore, the Brinell hardness data given by Model 4100 is only for reference.

2. Can Model 4100 use probe of hardness tester of other suppliers?

A: The probe used on Model 4100 is specially designed Leeb hardness probe from SADT, which meets the Leeb hardness measure standard. The probe is carefully calibrated before leaving the factory. For other hardness tester probes, Model 4100 may be not compatible, and the accuracy of the measurement cannot be guaranteed. Therefore, Model 4100 only use SADT's probe.

3. I need to measure the hardness of a new material, which is not one of the 12 materials supported by Model 4100. Can Model 4100 measure this new material?

A: Select Material is set for hardness unit conversion. For example, when the Leeb hardness values are the same, the HRC of different materials will be different. Select the correct material for correct conversion data. Model 4100 provide conversion data of 12 commonly used materials. If your material is not one of the 12 materials, the conversion data for its hardness value may be not accurate. If you choose Leeb hardness scale, the Leeb hardness value of the material is correct. The Leeb hardness is measured directly by the Leeb hardness tester and does not require conversion. If you need data of other hardness scales, we recommend that you contact us. We can help you develop new material hardness conversion table, and the datasheet will be added to Model 4100.

## **1.35. Wireless Micro printer**

### **1.35.1. Power on**

Press the power switch (left button) and hold down for 3 seconds, then the power is on. The status indicator flashes.

### **1.35.2. Power off**

Press the power switch (left button) and hold down for 3 seconds, then the power is off. The status indicator light turns off.

### **1.35.3. Feeding Paper**

Press the paper feed button (right button), the printer start feeding paper. If release the button, then stop feeding paper.

### **1.35.4. Self-test**

In the power-off state, press the paper feed button (right panel), do not release, and then power on. The printer will print self-test

### **1.35.5. Status Indication**

#### **1.35.6. Working Status Indication**

Printer head overheating, lacking paper, roll cover open: work status indicator flashes, the flashing period is 4 seconds (bright for 2 seconds)

Communication Status Indicator: When the printer is in stand-by station, the working status indicator light period is 4 seconds (bright for 50 milliseconds).

#### **1.35.7. Power Status Indication**

In the printer working process, the remaining capacity is more than 50%, three-color power indicator, green light keep bright; when the battery power 50% ~ 30%, three-color power indicator, the yellow light keep bright; when the battery is less than 30%, three-color power indicator, the red light keep bright; When the battery power is too low to support normal printing, the printer will automatically shut down

In the process of charging, the charger-color indicator light shows red. When charging is completed, three-color indicator light turns green.

#### **1.35.8. Precautions**

Operate the printer correctly; avoid any damage to the printer;

If jams occur, be sure to power off and wait for 10 seconds until the head is cooled down. Then remove the paper jam;

Do not place this product in wet or dusty environments; no pressing, stack forbidden;

Only use qualified paper roll (with axis);

Do not use paper roll with the end adhesive to the axis, otherwise the printer cannot measure the paper roll end correctly, or cause damage to the printer. Do not print data for long time.

**Sales and Service:**



BAQ GmbH  
Hermann-Schlichting-Straße 14  
38110 Braunschweig  
Germany

Phone +49 5307 95102 -0  
Fax +49 5307 95102 -20

<http://www.baq-inspection.vom>  
[info@baq.de](mailto:info@baq.de)